



Local Solutions For Individual Customers Worldwide

STAUFF Clamps



STAUFF Test



Filtration Technology



Diagtronics



Hydraulic Accessories



Valves



Flanges



ONE

Product Overview



That's STAUFF

Originating and located in Werdohl in the German Sauerland region, we have become an internationally leading developer, manufacturer and supplier of pipework components, measuring equipment and hydraulic accessories.

Decades of experience, highly-motivated and qualified staff, state-of-the-art manufacturing technologies and a foresighted management give us the reputation of being a competitive partner.

Our in-house laboratories carry out constant tests in line with international standards on all products. Certified in accordance with ISO 9001:2008 (Quality), DIN EN ISO 14001:2004 (Environmental Protection) and OHSAS 18001:2007 (Occupational Health and Safety), our management system continually strives for perfection.

Many of our products have been successfully tested and approved by several international organisations and institutes.

Our well-stocked warehouses and flexible production lines ensure prompt reactions and short delivery times.

Represented by a tight network of distributors and wholly-owned manufacturing facilities, distribution bases and warehouses in 18 countries worldwide, we are also close to you.

Our subsidiaries also supply additional retail products related to the hydraulics industry, thereby offering a near-complete range of industry-specific key products.



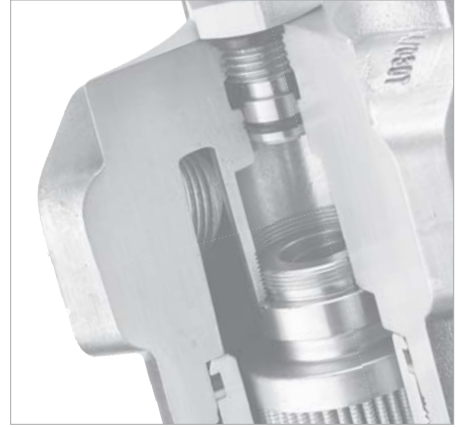
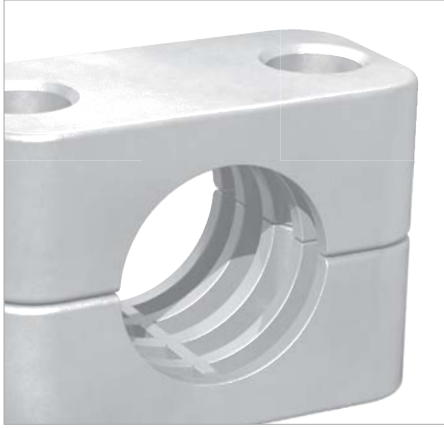

STAUFF Clamps

Clamping systems for pipes, tubes, hoses, cables and other components; custom-designed special clamps according to customer's requirements



Standard Series according to DIN 3015-1

- For diameters up to 102 mm
- Clamp bodies made of Plastic or Aluminium
- Installation equipment in Steel or Stainless Steel



Heavy Series according to DIN 3015-2

- For diameters up to 450 mm
- Clamp bodies made of Plastic or Aluminium
- Installation equipment in Steel or Stainless Steel



Twin Series according to DIN 3015-3

- For diameters up to 42 mm
- Also available for two different diameters
- Clamp bodies made of Plastic
- Installation equipment in Steel or Stainless Steel
- Also available as Heavy or Compact version



Saddle Clamps for Cylinder Supply Lines



Light Series

- Single or Double version available
- For diameters up to 32 mm
- Also available for two different diameters
- Clamp bodies made of Plastic
- Installation equipment in Steel or Stainless Steel



Construction Series

- For diameters up to 1000 mm
- Robust multi-part Steel construction
- For weld or bolt installation



Flat and Round Steel U-Boilts

- For diameters up to 521 mm
- U-Profile and accessories made of Steel or Stainless Steel
- Also available with Plastic Pipe Saddle
- Rubber-Shrouded versions available



Metal Pipe Clamps according to DIN 3567-A/B

- For diameters up to 521 mm



Light Saddles according to DIN 1592/93

Heavy Saddles according to DIN 1596/97

- For diameters up to 115 mm



Cushion Clamp Series



Custom-Designed Clamps

- Custom-designed clamping systems according to customer's specifications or based on STAUFF developments
- Clamp bodies made of Plastic or Metal
- Machined or injection moulded versions

STAUFF Test

Test couplings and hoses for the leakage-free connection of test devices for the monitoring of fluid technology systems



Test 20 - Connection Thread M16 x 2

- Available with ball check and piston valve
- Max. working pressure 630 bar / 9137 PSI
- Coupling at working pressure
- Available in Steel, zinc/nickel-plated C6F (CrVI-free) or Stainless Steel



Test 15 - Connection Thread M16 x 1,5

- Available with ball check and piston valve
- Max. working pressure 630 bar / 9137 PSI
- Coupling at working pressure
- Available in Steel, zinc/nickel-plated C6F (CrVI-free) or Stainless Steel



Test 12 - Connection Thread S12,65 x 1,5

- Available with piston valve
- Max. working pressure 630 bar / 9137 PSI
- Coupling at working pressure
- Available in Steel, zinc/nickel-plated C6F (CrVI-free) or Stainless Steel



Test 10 - Plug in System

- Available with ball check
- Max. working pressure 400 bar / 5801 PSI
- Coupling at working pressure
- Available in Steel, zinc/nickel-plated C6F (CrVI-free)



Adaptors

- Thread and Welding Adaptors
- Gauge Adaptor
- Sampling Hose Adaptor
- Hose Connector



Pressure Gauges and Accessories

- Stainless Steel Pressure Gauges
- Pressure Test Kits (consisting of test hoses, pressure gauges, test points, adaptors and accessories)
- Can be assembled according to customer's requirements



Test Hoses and Accessories

- Nominal bores DN2 and DN4
- Max. working pressure 630 bar / 9137 PSI
- Comprehensive range of Hose Ends

Filtration Technology

Filter systems for the basic equipment of mobile and industrial hydraulic applications; wide range of replacement filter elements



High Pressure Filters

- Max. working pressure up to 420 bar / 6000 PSI
- Max. flow rate up to 1320 l/min / 300 US GPM
- Available for different installation positions



Medium Pressure Filters

- Max. working pressure up to 160 bar / 2320 PSI
- Max. flow rate up to 1320 l/min / 300 US GPM



In-Line Filters

- Max. working pressure up to 14 bar / 200 PSI
- Max. flow rate up to 7000 l/min / 1850 US GPM



Return Line Filters

- Max. working pressure up to 34,5 bar / 500 PSI
- Max. flow rate up to 1135 l/min / 300 US GPM



Spin-On Filters

- Spin-On Filter Heads
- Comprehensive range of Spin-On Filter Elements
- Clogging Indicators



Offline / Bypass Filters

- Max. system volume up to 10800 l / 2853 gal
- Available with integrated motor/pump unit
- Several motor types available



Mobile Filter Units

- Nominal flow rate up to 110 l/min / 30 US GPM
- Several types available



Replacement Filter Elements

- Replacements for all major brands available
- More than 10000 different types
- Large stock-availability



Diagtronics

Analogue and digital pressure test systems for monitoring and analysis of hydraulic fluids (pressure, temperature, flow rate, rotational speed, contamination)



Pressure Gauges

- Analogue and digital pressure measuring of fluid and gaseous media
- Pressure Test Kits available with comprehensive accessories



Hydraulic Testers PPC-04/06/08-plus

- Digital measuring device for working pressure, temperature, flow rate and rotational speed
- Available with up to 6 sensor interfaces; automatic recognition and identification of connected sensors
- Total memory with up to 1 million measured values
- Permanent recording of MIN/MAX values



Hydraulic Tester PPC-Pad

- Portable multi-function hand-held measuring instrument
- Pressure, temperature, flow and speed can be measured, monitored and analysed
- Measurement and display of over 50 channels
- Measured value display: numerical, bar graph, pointer, curve graph
- Project templates can be saved and loaded
- Interfaces: CAN, LAN, USB
- Total memory with up to 1 billion measured values



Laser Particle Counters

- 8-channel particle counters for the contamination control of hydraulic fluids
- 3 versions available (portable, mobile, inline)
- Comprehensive range of accessories (e.g. Bottle Sampler)
- 4-channel particle counters for the permanent contamination control of hydraulic fluids



Sensors and Switches

- For continuous monitoring of critical hydraulic systems
- Wide range of STAUFF transmitters and switches are available
- Available in many pressure and temperature ranges

Flow Meters

Hydraulic Accessories

Components for the construction of hydraulic reservoirs and power units for the mobile and industrial hydraulic sectors



Level Gauges

- Visual/electrical level indication
- Also available with thermo sensors / switches for temperature indication



Filler Breathers

- Made of Plastic or Metal
- Different types and accessories



Giant Air Breathers

Desiccant Air Breathers

- Economy version or with check valves available
- Visual Contamination Indicator with adaptor plate



Suction Line Accessories

- Suction Strainers



Return Line Accessories

- Diffusers
- Return Line Bushings



Pipe, Tube and Hose Cleaning System



Two-Way Ball Valves

- Block, forged or round body design
- Different connection styles and sizes
- Available in Steel, zinc/iron-plated C6F (CrVI-free) or Stainless Steel



Multi-Way Ball Valves

- Block body design
- Three-way or four-way selector
- Available with L-, T- or double L-bore
- Different connection styles and sizes
- Available in Steel, zinc/iron-plated C6F (CrVI-free) or Stainless Steel



Flow Control Valves

- Throttle and shut-off the flow of liquid media in both directions or only in one direction (free flow in reverse direction)
- Also with pressure compensating
- Available in different designs (for in-line, manifold or cartridge assembly)
- Check Valves



Gauge Isolator Valves

- Effective protection of pressure gauges against overload caused by pressure peaks
- Multi station version for pressure measurement on six positions in the hydraulic circuit with only one pressure gauge



Our products are a driving force, whether on land, on water or in the air.

The exceptional quality of the equipment and the machines in which STAUFF products are used form the benchmark for the functionality and precision of the STAUFF product portfolio.

STAUFF products play a crucial role in many key sectors such as mobile and industrial hydraulics.

The complete portfolio is as varied as the sectors in which the products are used.

▪ Mobile Applications:

construction, forestry, agricultural and mining equipment; municipal vehicles; lifting and material handling; marine, railroad and automobile transportation; etc.

▪ Industrial Applications:

machines, engines and power units (metal-working machinery, iron and steel industry, injection moulding machinery, etc.); production, transportation and processing of oil and gas (on-shore and off-shore); wind power; nuclear plants and reactors; chemical and food processing industries; etc.

Flanges

Full range of SAE flanges (standard and high-pressure series) and gear pump flanges



SAE Flanges

- According to DIN ISO 6162-1/2 and SAE J 518C
- Standard and high-pressure series
- Nominal sizes DN13 to DN127
- Split flange halves and flange clamps
- Butt weld and socket weld adapters
- Both straight and 90° version available
- Male threaded adapters with 24° cone connector
- Single-part flanges available in different types (e.g. female threaded flanges, butt weld and socket weld flanges, male threaded flanges), both straight and 90° version available
- Flange blocks



Gear Pump Flanges

- In different types and sizes (e.g. 3- or 4-hole flanges)
- Both straight and 90° version available
- Threaded connections, butt weld and socket weld flanges, fitting and screw-in flanges



System Technology













Turned, milled, punched and bent parts

- All suitable materials such as Steel, Stainless Steel, non-ferrous metals or thermoplastics
- Various surface and heat treatments
- Size of up to 65 mm on automatic bar machines and up to 400 mm on automatic chuck lathes
- Production on modern single and multi-spindle automatic lathes, long turning automatic screw machines and CNC turning centers
- Permanent control of all production processes

Product Applications



Figures: 1. ThyssenKrupp Marine Systems AG; 2. Nordex AG; 3. Voith Paper GmbH & Co. KG

Overview	60	Oil Condition Sensor	75 - 77
Features & Options	61	Overview	75
Laser Particle Counter	62 - 68		Oil Condition Sensor 76
 Portable	62 - 63	Interface-OCS-I-USB	76
 Mobile	64 - 65		Oil Condition Display 77
 Bottle Sampler Unit	66		OCS Starterkit 77
 Accessories	67		
Technical Data (Overview)	68		
Particle Monitor	70 - 74		
 LPM-II	70		
 Interface-LPM-II-USB/ETH	71		
 Display-LPM-II-Remote	71		
 Flow Control Valve	72		
 ATEX Device	73		
 Oil Sampling Kit	74		



Laser Particle Counter ■ Type LasPaC-II



Fluid analysis is a crucial component of any oil management program. Early detection of potential problems can prevent costly repairs and downtime. The LasPaC-II makes it possible to detect the ISO Cleanness levels of the hydraulic media.

Characteristics

The LasPaC-II devices feature a twin laser system and eight channels for different particle sizes in order to guarantee high accuracy and repeatability. These compact units are easy to handle for mobile and inline applications for systems with pressures up to 400 bar / 5801 PSI.

The LasPaC-II is available in three different versions:

LasPaC-II-P: Portable Laser Particle Counter

The LasPaC-II-P is a fully equipped portable laser particle counter.

The LasPaC-II-P features a complete QWERTY keyboard, an integrated thermal printer, an internal rechargeable battery and a large LCD display.

LasPaC-II-M: Mobile Laser Particle Counter

The LasPaC-II-M is a highly accurate laser particle counter.

With a competitive price, the LasPaC-II-M is the best compromise between lower cost and brilliant accuracy/reliability.

All LasPaC-II devices have an internal data memory and are available within the accompanying Windows® based software package for reports and data downloads.

Overview

Options	LasPaC-II-P (Portable)	LasPaC-II-M (Mobile)	Bottle Sampler 110	Bottle Sampler 500	LPM-II
Laser Type	Twin-Laser	Twin-Laser	-	-	LED Laser
Analysis Range	8 channels (4,6,14,21,25,38,50,68 μm_d)	8 channels (4,6,14,21,25,38,50,68 μm_d)	-	-	8 channels (4,6,14,21,25,38,50,68 μm_d)
Power Supply	External	External	-	-	External
Battery Option	Internal	Internal (optional)	-	-	-
Display	Integrated (large)	Integrated (small)	-	-	Internal / External
Keyboard	Integrated	-	-	-	-
Printer	Integrated	-	-	-	-
Data Storage	Internal (for approximately 600 tests)	Internal (for approximately 600 tests)	-	-	Internal (for approximately 4000 tests)
PC Interface	RS-232	RS-232	-	-	RS485, RS232, Modbus, CAN Bus
Fluid Preparation	-	-	Integrated vacuum/pressure pump	Integrated vacuum/pressure pump	-
Maximal Bottle Size	-	-	110 ml	500 ml	-
Compatible with	Mineral oil and petroleum based fluids, Specific Water Glycol fluids or phosphate ester	Mineral oil and petroleum based fluids, Specific Water Glycol fluids or phosphate ester	Mineral oil and petroleum based fluids	Mineral oil, petroleum based fluids and Specific Water Glycol fluids or phosphate ester	Mineral oil and Specific Water Glycol fluids or phosphate ester



Laser Particle Counter - Type LasPaC-II

Features & Options: LasPaC-II (General)

Mobile - Compact and Convenient

The LasPaC-II-P (Portable), the LasPaC-II-M (Mobile) and all its accessories are supplied in a light-weight rugged industrial case.

This user-friendly portable case is waterproof and resistant against all common fluids.

Accuracy - Twin-laser, 100% Coverage

In all STAUFF laser particle counting devices, the fluid passes through the measuring cell and through a laser beam. The light from the laser is evaluated by a photo diode.

As the fluid passes through the laser beam the amount of light changes. These changes are directly proportional to size of the particles, and the total volume of particles. In many other particle counters only part of the measuring cell is lighted by the laser, thus only a part of the total amount of particles are registered, and the result is projected.

In contrast, the measuring cell of the LasPaC-II is completely examined, and all particles are registered. In addition to this, a second laser is used to analyze all particles sizes smaller than 6 $\mu\text{m}_{(e)}$.

Additionally, the integrated booster cylinder allows very precisely dosage of the test fluids. This ensures a very high accuracy with excellent repeatability.

Functional - Calibration to ISO 11 171

The LasPaC-II devices are calibrated with ISO Medium Test Dust (MTD) based on the ISO 11 171:1999 calibration standard.

STAUFF particle counters meet the new ISO 4406 cleanliness classification codes and provide results in the NAS 1638 and the SAE 4059 codes.

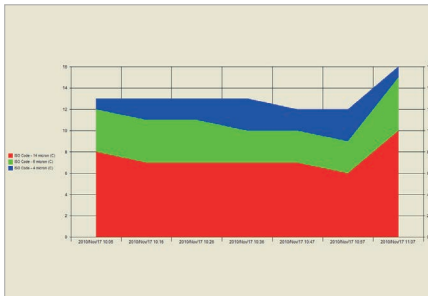

For any Type of Application - Large Pressure Range

A big advantage of the LasPaC-II devices is the wide pressure range: Low pressure measurements starting with 2 bar / 29 PSI and high pressure tests up to 400 bar / 5801 PSI result in reliable readings. Many other products available today require special add-on devices or pressure cartridges which need to be recharged for this.

The test hoses, which are provided with the device, allow an easy connection to common test couplings M16 x 2 (STAUFF TEST 20 or comparable).

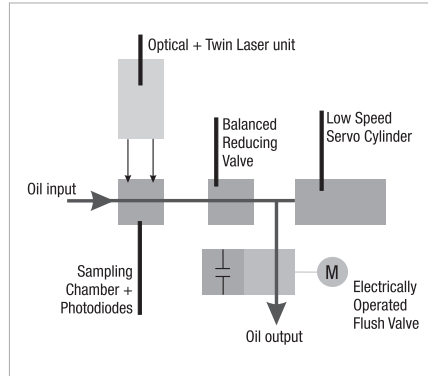

Global Use - Variable Voltage Supply

The external power supply unit provides most variable voltage ranges of 110 ... 240 V AC. European, UK and US plug adaptors ensure a worldwide applicability of the LasPaC-II.

Always Secure - External Alarms

The LasPaC-II-P devices offer the opportunity to define different alarm levels.

It is possible to configure two separate contamination alarm levels (e.g. clean alarm level and dirt alarm level). When set, an alarm indicator is given to external devices (e.g. indicator light, offline-filter) if the alarm level is reached.

Making the Connection -

Downloading with RS-232 Interface and USB Adaptor

The measured data can be downloaded onto any PC or laptop computer via the RS-232 interface or alternatively via a USB adaptor.

The LasPaC-II software supports an easy download for data processing of the recorded measurements.

Several diagrams are available and are automatically generated to offer a very clear arrangement of all data for analysis. Data can also be easily exported to Microsoft Excel®.

Always up-to-date - Integrated Clock

An integrated rechargeable battery-operated clock provides the exact date and time which are shown on every printout.

In addition, every download of measured data is marked with date and time as well. The precise time of measurement is documented on all printouts and for all data stored.

Adaptable - Software Updates

The RS-232 (or USB) interface ensures flexibility for future developments in terms of calibration, evaluation and output. Software updates can easily be installed onto the LasPaC-II devices.

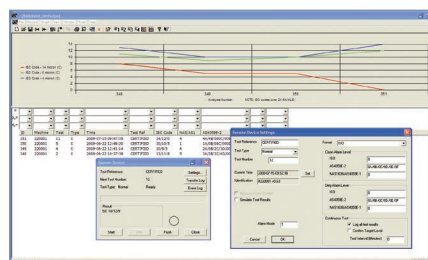

Cleanliness - High-Speed Flush Valve

To ensure an accurate measurement is taken, the sensor must be cleaned before each test.

The LasPaC-II achieves this by means of an electric operated flush valve. This valve can be opened on demand and between tests by simply depressing the flushing valve push button. The optimized design of the flush valve reduces the rinsing process to the minimum requirement, and ensures a quick restart of the next measurement.

For all Applications - High Compatibility

The LasPaC-II units are compatible with all Mineral Oil and Petroleum based fluids. Phosphate Ester (e.g. Skydrol®) and Water Glycol compatible devices are available upon request. Please contact STAUFF for details.

More Oil Information - The Moisture/ Temperature Sensor

The LasPaC-II also offers the option of adding an integral moisture / temperature sensor.

This sensor measures the moisture content of the test fluids (displayed as relative humidity in RH %) and also indicates the current fluid temperature (in °C).

Please note that the moisture/ temperature sensor is not compatible with Phosphate Ester (e.g. Skydrol®) and Water Glycol fluids.

For further information please see on page 67.

Optional - Bottle Sampling Unit

Highly aerated fluids may lead to inaccurate results.

Therefore a de-aeration facility has been incorporated into the optional bottle sampling units.

Both sizes (110 ml and 500 ml) of the bottle sampling unit are delivered with an external power supply, and allow the user to properly condition the sample fluid prior to any measurements taken. For further information please see on page 66.

Please note that the moisture/ temperature sensor as mentioned above does not work in conjunction with the bottle sampling unit.

Scope of Delivery

Each kit of a laser particle counter STAUFF LasPaC-II includes:

- 1x Laser particle counter STAUFF LasPaC-II
- 1x LasPaC-II-M / LasPaC-II-P: Waste hose 2 m / 3.65 ft
- 1x Pressure hose: 1,5 m / 2.67 ft
- 1x Waste bottle
- 1x External power supply including cable with European, UK and USA plug adaptors
- 1x RS-232 connecting cable, 1 m / 1.78 ft including RS-232 to USB converter
- 1x Software CD "LasPaC-II View"
- 1x User guide LasPaC-II
- 1x User guide LasPaC-II View
- 3x Thermal printer paper (only with LasPaC-II-P)



Laser Particle Counter - Type LasPaC-II-P (Portable)



Light-Weight Rugged Industrial Case



Integrated Printer

C

Product Description

The LasPaC-II-P (Portable) is the most complete way to measure the contamination level of your system. With the LasPaC-II-P you have the ability to measure, analyze and document your results immediately without the need of any additional equipment.

Features

Quick Results - Fast Results and Easy Operation

The integrated complete QWERTY keyboard, a large LCD display and intuitive handling all lead to the easy and quick operation of the LasPaC-II Portable. The optimized flushing process of the LasPaC-II-P is quick and effective, and allows for continuously accurate measurements.

Black and White - Integrated Printer

The integrated printer in the LasPaC-II-P supports print-outs in the field, thus providing immediate documentation. Every printout confirms date and time of your measurement.

Independent Use - Rechargeable Battery Mode

The integrated rechargeable battery of the LasPaC-II-P allows the use of on site measurements, even in the event where access of an external power source is not available. The measurement data is stored in the internal memory of the unit and can be transferred to a computer when required.

Once charged the LasPaC-II-P can run approximately 100 tests before recharging is needed again.

Options

- **Moisture / Temperature Sensor**
This sensor measures the moisture content of the test fluids (displayed as relative humidity in RH %) and also indicates the current fluid temperature (in °C). For further information please see on page 67.
- **Phosphate Ester (e.g. Skydrol®) or specific Water Glycol fluids units on request**

Order Codes

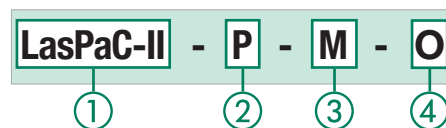

① Series and Types

Laser Particle Counter **LasPaC-II**

② Version

Portable **P**

③ Fluid Compatibility

Mineral Oil, Petroleum based fluids (standard option) **M**
Phosphate Ester (e.g. Skydrol®) **E**
Specific Water Glycol fluids **G**

④ Moisture/ Temperature Sensor

Without moisture/ temperature sensor **O**
With moisture/ temperature sensor **W**

Please note: The moisture/ temperature sensor is not suitable for Phosphate Ester (e.g. Skydrol®) and Water Glycol fluids.



Laser Particle Counter ■ Type LasPaC-II-P (Portable)



Highspeed Flush Valve



Computer Interfaces of the LasPaC-II-P



Easy Connection to common Test Couplings

Technical Data

Dimensions and Weight

- L/W/H: 551 x 358 x 226 mm / 21.69 x 14.09 x 8.90 in
- Weight: 13 kg / 28.66 lbs

Keyboard / Printer

- Keyboard: QWERTY keyboard
- Printer: Integrated thermal printer (384 dots per line)

Power Supply

- Voltage range: 110 ... 240 V AC / 12 ... 24 V DC
- European, UK and US power plug adaptors included
- Number of tests before recharging is required: 100

Calibration

- Calibration: ISO Medium Test Dust (MTD) according to ISO 11 171:1999
- Analysis range: ISO 8-24, ISO 4406 Code, NAS 1638 Code 2-12, SAE AS 4059 Code 2-12

Pressure / Viscosity

- Pressure range: 2 ... 400 bar / 29 ... 5801 PSI
- Viscosity range: 1 ... 400 cSt

Laser Sensors

- High accuracy laser: 4 ... 6 $\mu\text{m}_{(e)}$
- Standard accuracy laser: 6 ... 68 $\mu\text{m}_{(e)}$
- Measured channels: 4, 6, 14, 21, 25, 38, 50, 68 $\mu\text{m}_{(e)}$
- The orifice of the sensor has a cross section of 0,9 x 0,9 mm / .04 x .04 in
- The maximum concentration is ISO 4406 Code 24 (160.000 p/ml)

Accessories

- Bottle Sampling Unit 110 ml (for Mineral Oil and Petroleum based fluids)
- Bottle Sampling Unit 500 ml (for Mineral Oil and Petroleum based fluids)
- Bottle Sampling Unit 500 ml (Version E) (for Phosphate Ester (e.g. Skydrol®) available on request) For further information please see on page 66.
- Screen filter: 500 μm (see on page 67)

Hose Connections

- Test coupling STAUFF Test 20 or comparable (M16 x 2)

Sample Volume

- 8 ml (short)
- 15 ml (normal)
- 30 ml (dynamic)
- 24 ml (bottle sampler)
- 15 ml (continuous)

Permissible Temperature

- Operating: +5 °C ... +80 °C / +41 °F ... +176 °F

Data Output

- Cumulative particle counts, as well as cleanliness classes according to ISO 4406 (1999) / SAE AS 4059 Rev.D (2001) and ISO 4406 (1191) / NAS 1638 (1964)

Max. Concentration

- ISO 24

Accumulator

- Internal rechargeable battery

Data Storage

- 600 tests

Fluid Compatibility

- Mineral Oil, Petroleum based fluids
- Phosphate Ester and Water Glycol compatible devices on request

Computer Interface

- RS-232 communication port as standard
- USB adaptors included

External Alarm

- External alarm socket with switching outputs max. 24 V DC/AC, 1 A

Software

- Downloading and storage of the data with included "LasPaC-II View" software. Further processing with Microsoft Excel® possible.



Laser Particle Counter - Type LasPaC-II-M (Mobile)



LasPaC-II-M with integrated battery (standard option)



LasPaC-II-M also available without integrated battery

Product Description

The LasPaC-II-M is a highly accurate laser particle counter. With a competitive price, the LasPaC-II-M is the best compromise between lower cost and brilliant accuracy/reliability.

Features

Versatile - Lightweight and Convenient

The LasPaC-II-M (Mobile) is designed for applications where it is necessary to have a small, light and robust service unit.

Low Cost - Same Functions for a Budget Price

Without losing the quality in measurement accuracy, reliability and repeatability the LasPaC-II-M is a cost effective alternative to the fully equipped LasPaC-II-P.

Options

- **Moisture / Temperature Sensor**
This sensor measures the moisture content of the test fluids (displayed as relative humidity in RH %) and also indicates the current fluid temperature (in °C). For further information please see on page 67.
- **Phosphate Ester (e.g. Skydrol®) or specific Water Glycol fluids units on request**
- LasPaC-II-M also available without integrated battery

Order Codes

LasPaC-II - M - M - O - B				
①	②	③	④	⑤
① Type and Series				
Laser Particle Counter			LasPaC-II	
② Version				
Mobile			M	
③ Fluid Compatibility				
Mineral Oil, Petroleum based fluids (standard option)			M	
Phosphate Ester (e.g. Skydrol®)			E	
Specific Water Glycol fluids			G	
④ Moisture/ Temperature Sensor				
Without moisture/ temperature sensor			O	
With moisture/ temperature sensor			W	
Please note: The moisture/ temperature sensor is not suitable for Phosphate Ester (e.g. Skydrol®) and Water Glycol fluids.				
⑤ Battery				
With internal rechargeable battery (standard option)			B	
Without internal rechargeable battery			O	



Laser Particle Counter ■ Type LasPaC-II-M (Mobile)



LasPaC-II-M with small Bottle Sampler



Display and Buttons

Technical Data
Dimensions and Weight

- L/W/H: 340 x 295 x 152 mm /
13.40 x 11.61 x 5.98 in
- Weight: 4,75 kg / 10.47 lbs

Power Supply

- Voltage range: 110 ... 240 V AC
12 ... 24 V DC
- European, UK and US power plug adaptors included
- Number of tests before recharging is required: 60

Calibration

- Calibration: ISO Medium Test Dust (MTD)
according to ISO 11 171:1999
- Analysis range: ISO 8-24, ISO 4406 Code,
NAS 1638 Code 2-12,
SAE AS 4059 Code 2-12

Pressure / Viscosity

- Pressure range: 2 ... 400 bar / 29 ... 5801 PSI
- Viscosity range: 1 ... 400 cSt

Laser Sensors

- High accuracy laser: 4 ... 6 $\mu\text{m}^{(c)}$
- Standard accuracy laser: 6 ... 68 $\mu\text{m}^{(c)}$
- Measured channels: 4, 6, 14, 21, 25, 38, 50, 68 $\mu\text{m}^{(c)}$
- The orifice of the sensor has a cross section of
0,9 x 0,9 mm / .04 x .04 in
- The maximum concentration is ISO 4406 Code 24
(160.000 p/ml)

Accessories

- Bottle Sampling Unit 110 ml
(for Mineral Oil and Petroleum based fluids)
- Bottle Sampling Unit 500 ml
(for Mineral Oil and Petroleum based fluids)
- Bottle Sampling Unit 500 ml (Version E)
(for Phosphate Ester (e.g. Skydrol®) available on request)
For further information please see on page 66.
- Screen filter: 500 μm (see on page 67)

Hose Connections

- Test coupling STAUFF Test 20 or comparable (M16 x 2)

Sample Volume

- 8 ml (short)
- 15 ml (normal)
- 30 ml (dynamic)
- 24 ml (bottle sampler)
- 15 ml (continuous)

Permissible Temperature

- Operating: +5 °C ... +80 °C / +41 °F ... +176 °F

Data Output

- Cumulative particle counts, as well as cleanliness classes
according to ISO 4406 (1999) / SAE AS 4059 Rev.D (2001)
and ISO 4406 (1191) / NAS 1638 (1964)

Max. Concentration

- ISO 24

Data Storage

- 600 tests

Fluid Compatibility

- Mineral Oil, Petroleum based fluids
- Phosphate Ester and Water Glycol compatible devices on
request

Computer Interface

- RS-232 communication port as standard
- USB adaptors included

Software

- Downloading and storage of the data with included
"LasPaC-II View" software. Further processing with
Microsoft Excel® possible.

Internal Rechargeable Battery

- Standard option with internal rechargeable battery



Bottle Sampling Unit ▪ Typ Bottle-Sampler-LasPaC-II



Bottle Sampling Unit 110 ml and Accessories



Bottle Sampling Unit 110 ml



Bottle Sampling Unit 500 ml

Product Description

Analysis Everywhere - Bottle Sampling Unit

If a direct particle count on your system is not possible, the LasPaC-II bottle sampler units allow you to take measurement samples for analysis at a later time.

Conditioning - The De-aeration Facility

A highly aerated fluid may lead to inaccurate results; therefore a de-aeration process has been incorporated into the bottle sampling units.

By evacuating the air from the sampling chamber, aeration within the fluid is removed, and the fluid is properly conditioned prior to sampling.

Your Choice - 110 ml or 500 ml Size

STAUFF offers two sizes of bottle sampling units for the LasPaC-II devices: the 110 ml and the 500 ml units.

The 110 ml unit is supplied in an extra case including various accessories such as power supply, sampling hoses, pressure hoses, bottles (sample and waste) and adaptors. It is designed for mobile applications and is only compatible with Mineral Oil and Petroleum based fluids.

The standard version of the 500 ml unit is compatible with Mineral Oil and Petroleum based fluids; a Phosphate Ester (e.g. Skydrol®) compatible version of the 500 ml unit is available on request. Please contact STAUFF for details.

The 500 ml bottle sampling unit is delivered with the required power supply.

Please note that the moisture / temperature sensor does not work in combination with bottle sampler devices.

Order Codes



① Bottle Sampling Unit

Bottle Sampling Unit **Bottle-Sampler**

② Type and Series

Laser Particle Counter **LasPaC-II**

③ Unit

110 ml Bottle Sampling Unit suitable for Mineral Oil and Petroleum based fluids only	110-M
500 ml Bottle Sampling Unit suitable for Mineral Oil and Specific Water Glycol fluids, Petroleum based fluids only	500-M/G
500 ml Bottle Sampling Unit suitable Phosphate Ester (e.g. Skydrol®)	500-E



Moisture / Temperature Sensor

Product Description

More Oil Analysis - Oil Saturation and Temperature

In Mineral Oils and non-aqueous fire resistant fluids, water is undesirable. Once the water exceeds a saturation level (about 500 ppm for Mineral Oils) the fluid starts to appear hazy. Above this level there is a danger of free water accumulating in the system. This can lead to corrosion and accelerated wear.

As an option, all LasPaC-II devices provide accurate and repeatable measurement of the saturation level of water in oil with the moisture / temperature sensor. The sensor is located internally in a specially designed housing and is positioned in the low pressure constant flow line.

Additional Information - Oil Temperature Readings

Beside the saturation level the optional moisture / temperature sensor of the LasPaC-II units has the ability to measure the fluid temperature. This allows to provide a reference temperature for the RH (relative humidity / % saturation of water in oil) readings.

Both results, RH % and °C, are displayed on the main / test progress screen and on the printed analysis.

Please note: Due to the temperature gradient existing between the system tapping point and the RH / temperature module, the temperature reading can be 5° to 10° less than the actual system temperature, depending on operating conditions. The moisture / temperature sensor is not suitable for bottle sampling.

Saturation Levels

Since the effects of free (also emulsified) water are more harmful than those of dissolved water, water levels should remain always well below the saturation point.

However, even water in solution can cause damage, and therefore every reasonable effort should be made to keep saturation levels as low as possible.

There is no such thing as too little water. As a guideline, we recommend maintaining saturation levels below 50 % in all equipment.

Different oils have different saturation levels, and % saturation is the best and most practical measurement.

These results can be converted to ppm (parts per million), if the oil type saturation / temperature characteristic is known.

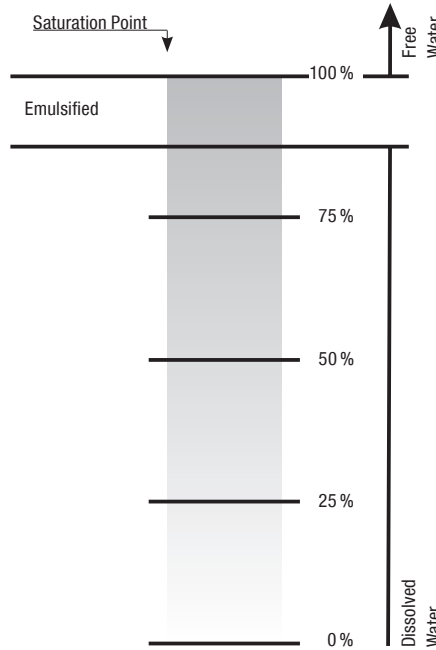

Laser Particle Counter - Accessories



Order Codes

Accessories / Spare Parts



1 Type of Accessories / Spare Parts

Waste hose 2 m / 6.56 ft	Hose-LasPaC-II-Waste-2m
Pressure hose 1,5 m / 4.92 ft	SMS-20-1500-A-W3
110 ml certified clean bottle (5 pieces)	Set-Bottle-LasPaC-II-110-C
250 ml certified clean bottle (5 pieces)	Set-Bottle-LasPaC-II-250-C
110 ml glass sample bottle (5 pieces)	Set-Bottle-LasPaC-II-110
250 ml glass sample bottle (5 pieces)	Set-Bottle-LasPaC-II-250
500 ml glass sample bottle (5 pieces)	Set-Bottle-LasPaC-II-500
Printer paper LasPaC-II-P (5 pieces)	Set-Paper-LasPaC-II-Printer
RS 232 to USB converter	Adaptor-PPC-04/12-RS232-to-USB-CAB
Screen filter	Screen-Filter-LasPaC-II



Product Description: Screen Filter

An optional Screen Filter is available for heavily contaminated systems. The filter device is assembled directly to the supply line and allows particle counts in ambient conditions where normally the contamination is too high for a reliable test.

The Stainless Steel Filter has a mesh of 500 µm and is cleanable.



Laser Particle Counter ■ Technical Data

			
Type	LasPaC-II-P (Portable)	LasPaC-II-M (Mobile)	LPM-II
Dimensions (mm/in) (W x D x H)	551 x 358 x 226 21.69 x 14.09 x 8.90	340 x 295 x 152 13.40 x 11.61 x 5.98	141 x 116 x 63,5 5.55 x 4.57 x 2.5
Weight (kg/lbs)	13 28.66	4,75 10.47	1,15 2.53
Keyboard	QWERTY keyboard integrated	-	5 Button Display Settings
Printer	Thermal printer integrated (384 dots per line)	-	-
Viscosity Range	1 ... 400 cSt	1 ... 400 cSt	<= 1000 cSt
Calibration	MTD, ISO 11 171:1999	MTD, ISO 11 171:1999	MTD, ISO 11171:1999
Analysis Range	ISO 8-24, ISO 4406 Code, NAS 1638 Code 2-12, SAE AS 4059 Code 2-12	ISO 8-24, ISO 4406 Code, NAS 1638 Code 2-12, SAE AS 4059 Code 2-12	ISO 8-24, ISO 4406 Code, NAS 1638 Code 2-12, SAE AS 4059 Code 2-12
Sensitivity	4, 6, 14, 21, 25, 38, 50, 68 $\mu\text{m}_{(c)}$	4, 6, 14, 21, 25, 38, 50, 68 $\mu\text{m}_{(c)}$	4, 6, 14, 21, 25, 38, 50, 68 $\mu\text{m}_{(c)}$
Sample Volume	8 ml (short) 15 ml (normal) 30 ml (dynamic) 24 ml (bottle sampler) 15 ml (continuous)	8 ml (short) 15 ml (normal) 30 ml (dynamic) 24 ml (bottle sampler) 15 ml (continuous)	Adjustable by user
Pressure Range (bar/psi)	2 ... 400 29 ... 5801	2 ... 400 29 ... 5801	Please refer differential pressure diagram
Operating Temperature (°C/°F)	+5 ... +80 +41 ... +176	+5 ... +80 +41 ... +176	-25 ... +80 -13 ... +176
Max. Concentration	ISO 24	ISO 24	ISO 24
Power Supply	110 ... 240 V AC 12 ... 24 V DC	110 ... 240 V AC 12 ... 24 V DC	110 ... 240 V AC 9 ... 36 V DC, <2,2W
Battery	Internal rechargeable battery	Internal rechargeable battery	-
Data Storage	600 tests	600 tests	4000 tests
Fluid Compatibility	Mineral Oil / Petroleum based fluids; Phosphate Ester and water glycol compatible devices on request	Mineral Oil / Petroleum based fluids; Phosphate Ester and Water Glycol compatible devices on request	Mineral Oil / Petroleum based fluids; Phosphate Ester and Water Glycol compatible devices on request
PC Interface	RS-232	RS-232	RS-232
External Alarm	External alarm socket	-	External Alarm
Hose Connections	Test coupling STAUFF Test 20 or comparable (M16 x 2)	Test coupling STAUFF Test 20 or comparable (M16 x 2)	Test coupling STAUFF Test 20 or comparable (M16 x 2)
Accessories	Moisture/temperature sensor Bottle sampling unit (110 ml / 500 ml) Screen filter (500 μm)	Moisture/temperature sensor Bottle sampling unit (110 ml / 500 ml) Screen filter (500 μm)	Remote Display Interface Module Flow Control Valve



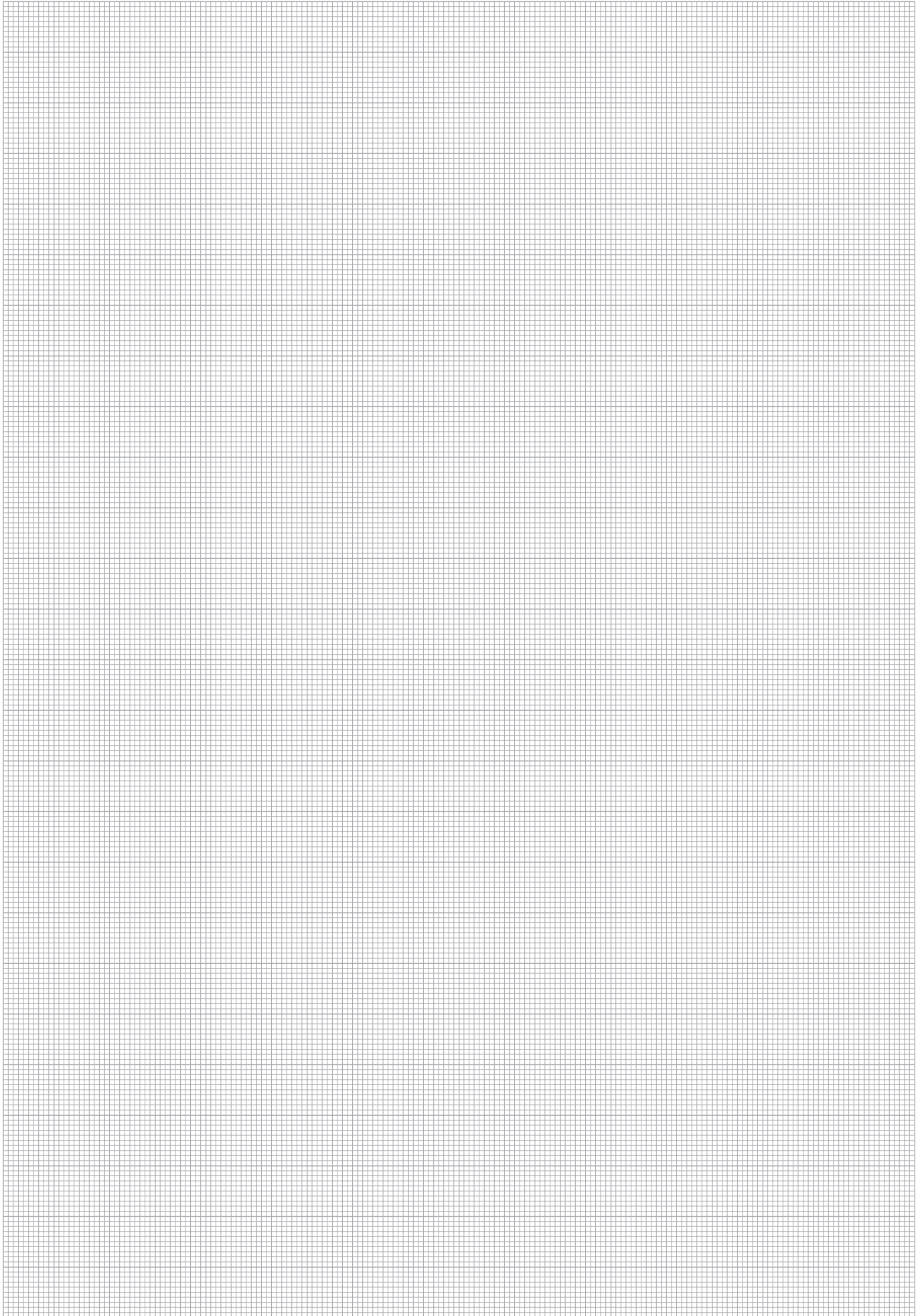

Particle Monitor ▀ LPM-II

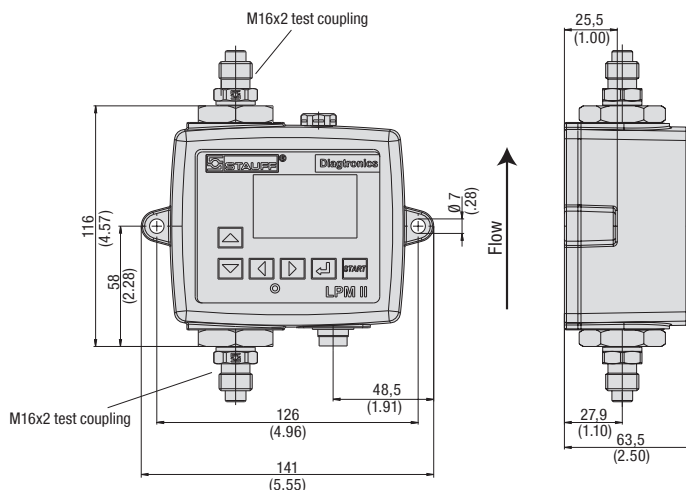

Product Description

The LPM-II Particle Monitor determines the contamination level of the measured fluid on eight size channels and offers precise and complete determination of particle sizes in accordance with international standards.

The LPM-II is an automatic, optical particle counter with high-performance LEDs that work on the light obscuration principle. STAUFF recommends recalibrating the measuring equipment at regular intervals.

Options

- Moisture sensor / temperature sensor: RH in % (relative humidity) and temperatures in °C
- Phosphate Ester- (e.g. Skydrol®) and Water Glycol-compatible devices are available on request

Technical Data

Channels

- >4, 6, 14, 21, 25, 38, 50, 70 µm(c) according to ISO 4406:1999

Measuring Range / Purity Classes

- ISO 4406:1999 Code 0 to 25, NAS 1638 Class 00 to 12, AS4059 Rev. E. Tables 1 and 2 Sizes A-F: Classes 000 to 12, ISO 11218 Classes 00 to 12 (lower codes or classes are test time-dependent)

Precision

- ±1/2 Code for 4, 6, 14 µm(c)
- ±1 Code for larger particles

Calibration

- Each device is individually calibrated using ISO Medium Test Dust (MTD) in accordance with ISO 11171 (1999);

Flow

- 20 ... 400 ml/min / 0.005 ... 0.11 US GPM

Viscosity Range

- ≤ 1000 mm²/s

Medium Temperature

- 25 °C ... +80 °C / -13 °F ... +176 °F *pressure-dependent

Ambient Temperature

- LMP II-O: -25 °C ... +80 °C / -13 °F ... +176 °F
- LMP II-D: -25 °C ... +55 °C / -13 °F ... +131 °F

Weight

- 1.15 kg / 2.53 lbs

Order Codes

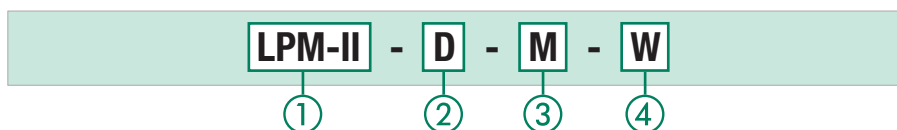

① Series and Type

Particle Monitor **LPM-II**
(Incl. LPM-II-CAB-P-FL-3 connecting cable)

② Version

With display and keypad **D**
Without display and keypad **O**

③ Fluid Compatibility

Fluids based on Mineral Oil and Petroleum (standard) **M**
Phosphate Ester (e.g. Skydrol®) **E**
Specific Water Glycols **G**

Note: If you have any queries on fluid compatibility, please contact STAUFF.

④ Moisture Sensor / Temperature Sensor

Without moisture sensor / temperature sensor **O**
With moisture sensor / temperature sensor **W**

Note: In the case applications with extreme pressure peaks, please contact STAUFF.

Note: Versions "E" and "G" can only be supplied without moisture sensor / temperature sensor

Note: You need an interface module with either a USB or an Ethernet interface for exporting and programming.

Fluid Compatibility

- M:** suitable for Synthetic and Mineral Oil based fluids, Diesel and Petroleum
- G:** Austenitic Stainless Steel, FKM/FPM (Viton®): suitable for offshore and aqueous fluids
- E:** Austenitic Stainless Steel, Perfluorinated Rubber (FFKM): suitable for Phosphate Ester and aggressive media

Max. Permissible Operating Pressure

- 400 bar / 5801 PSI static *temperature-dependent (Note: In systems with extreme pressure peaks, please contact STAUFF)

Test Duration

- Settable between 10 ... 3600 sec., set ex-works to 120 sec.
- As standard with start delay and freely programmable test intervals

Moisture Sensor / Temperature Sensor

- % RH (relative humidity) ±3 %
- ±3 °C / ±32 °F

Volumetric Flow Measurement

- As display only

Hose Connections

- Test coupling STAUFF Test 20 or comparable (M16 x 2)

Data Storage

- Max. 4000 measuring results

Interfaces

- RS485, RS232, Modbus, CAN Bus

International Protection Rating

- IP 65: Dust-proof and protected from spray
- Impact resistance rating IK04

Power Supply / Power

- 9 ... 36 V DC, < 2.2 W (connecting cable with flying leads is included)

Current Consumption

- 12 V: 70 mA (LPM-II-O), 150 mA (LPM-II-D)
- 24 V: 40 mA (LPM-II-O), 80 mA (LPM-II-D)
- 36 V: 30 mA (LPM-II-O), 60 mA (LPM-II-D)

Housing Surface Treatment

- Painted, Polyurethane based paint, according to BSX34 colour BS381-638 (dark grey)
- Tested according to: BS2X34A and BS2X34B, MMO114 and SP-J-513-083 Part II. Cl. A
- The unit meets: MIL-PRF-85285

Wetted parts

- M:** C46400 Cu Alloy, 316 Stainless Steel, FKM/FPM (Viton®), FR4, Sapphire
- G:** 316 Stainless Steel, FKM/FPM (Viton®), Sapphire
- E:** 316 Stainless Steel, Perfluorinated Rubber (FFKM), Sapphire, EPDM



Interface Module with USB or Ethernet Interface ▪ INTERFACE -LPM-II-USB/ETH

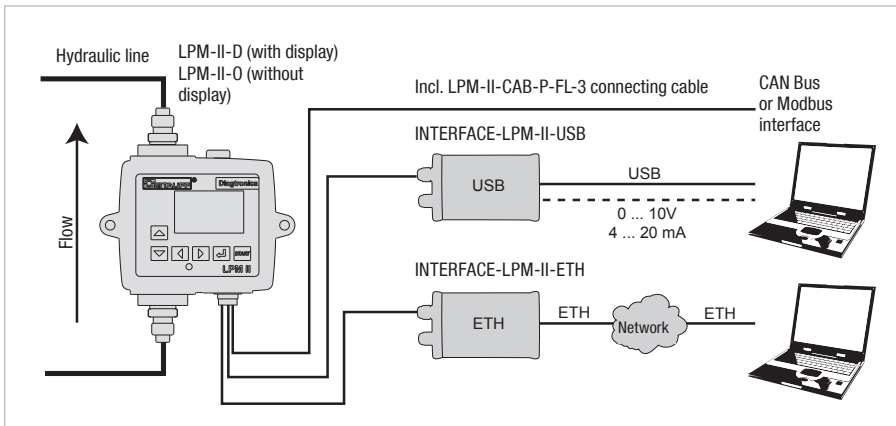

Connection diagram: PC connection of the LPM-II Particle Monitor

Order Code

INTERFACE-LPM-II-USB



① Series and Type

- Interface module with USB interface **INTERFACE-LPM-II-USB**
- Interface module with USB interface **INTERFACE-LPM-II-USB-010V**
- Interface module with USB interface **INTERFACE-LPM-II-USB-420A**

Scope of supply:

- Power supply unit
- Interface module with USB interface
- Connecting cable (3 m / 9.84 ft)
- USB cable

Order Code

INTERFACE-LPM-II-ETH



① Series and Type

- Interface module with Ethernet interface **INTERFACE-LPM-II-ETH**

Scope of supply:

- Power supply unit
 - Interface module with Ethernet interface
 - Connecting cable (3 m / 9.84 ft)
- Note: An Ethernet cable is not supplied.

Product Description

The LPM-II is connected to an EDP system or a laptop/PC using an interface module with a USB or an Ethernet interface.

Either interface module is connected to the LPM-II using a connecting cable (3 m / 9.84 ft). With the power supply unit connected, the LPM-II is supplied with current via the connecting cable.

The interface modules allow you to evaluate the measured data and to carry out programming using the supplied software.

In USB operation, the LPM-II can be supplied with current via the USB cable too.

The USB interface is optionally also available with additional 0-10 V or 4-20 mA outputs. The 0-10 V interface provides six ISO channels, the relative humidity and the temperature on eight voltage outputs. The 4-20 mA version, on the other hand, supplies e.g. the NAS code and the relative humidity on two outputs.

Remote Display Unit ▪ DISPLAY-LPM-II-REMOTE

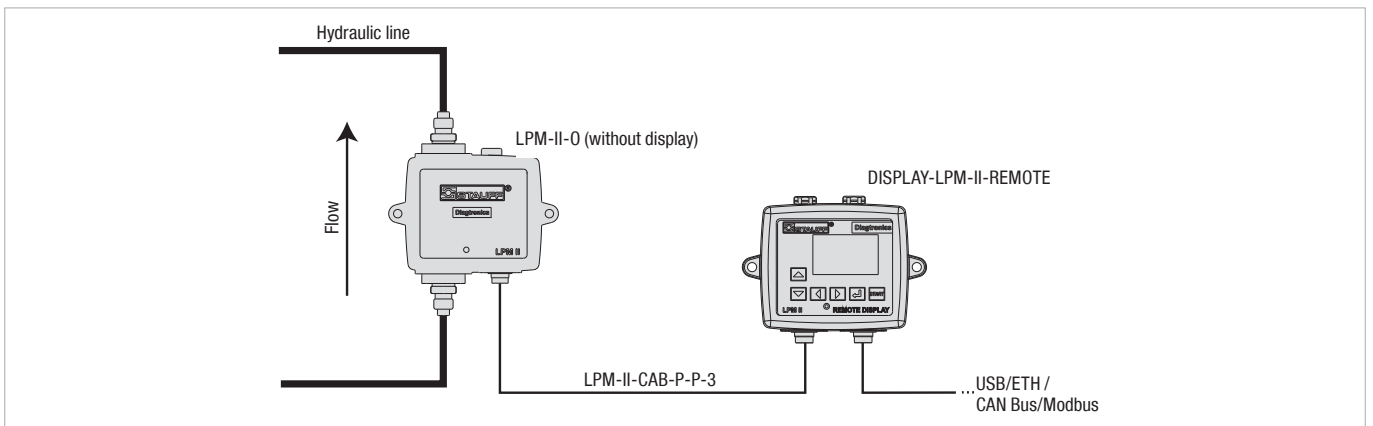

Connection diagram: Remote display

Order Code

DISPLAY-LPM-II-REMOTE



① Series and Type

- DISPLAY-LPM-II-REMOTE**

Scope of supply:

- Remote Display
- LPM-II-CAB-P-P-3 connecting cable

Product Description

In the case of applications outside the operator's field of view or in locations that are difficult to access, it is possible to display via a remote display the values that the LPM-II measured.



Flow Control Valve - LPM-II-DAV

C

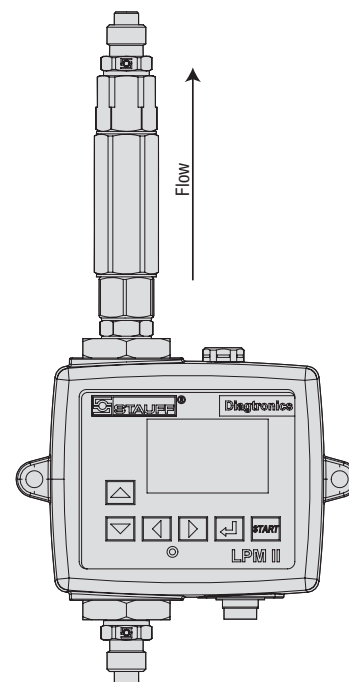
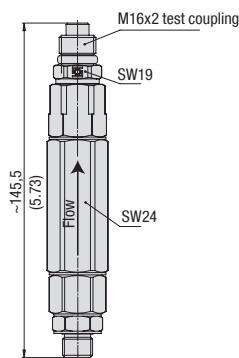

LPM-II with flow control valve LPM-II-DAV

Product Description

In systems in which the volumetric flow or the pressure is too high, the optimum flow is achieved with the use of a flow control valve.

It can process pressures from 4 bar ... 400 bar / 58 PSI ... 5801 PSI.

The LPM-II-DAV, flow control valve is connected to the hydraulic outlet of the LPM-II via the connection fittings.

Max. Permissible Operating Pressure

- 400 bar / 5801 PSI

(Note: Note that a minimum operating pressure of 4 bar / 58 PSI must be maintained for the proper function of the flow control valve.)

Order Code

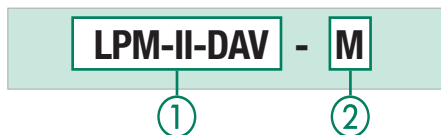

1 Series and Type

Flow Control Valve **LPM-II-DAV**

2 Fluid Compatibility

Fluids based on Mineral Oil and Petroleum (standard) **M**
 Phosphate Ester (e.g. Skydrol®) **E**
 Specific Water Glycols **G**

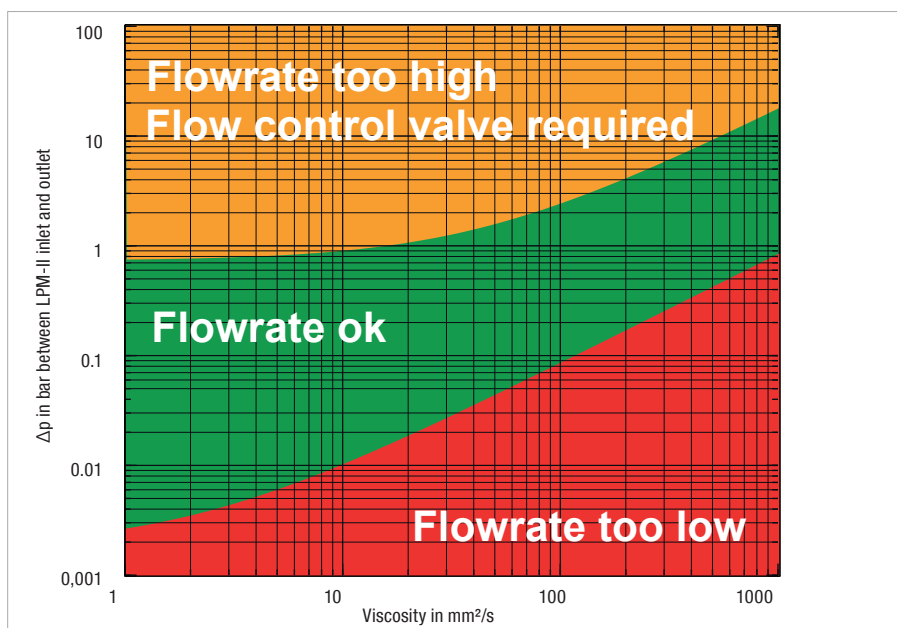

Particle Monitor ■ LPM-II-...-CX

Wiring Diagram

Note: Please note that an ATEX approved connecting cable is not included in the scope of delivery of LPM-II-0-...-CX. A corresponding ATEX plug is included.

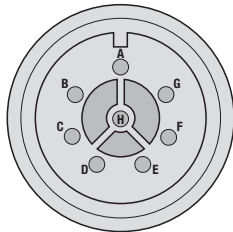

View A (Sensor)

- A Data+
- B Test start
- C Data-
- D Output
- E I/C Common
- F Output 2
- G Power 0V
- H Power +12-24V DC

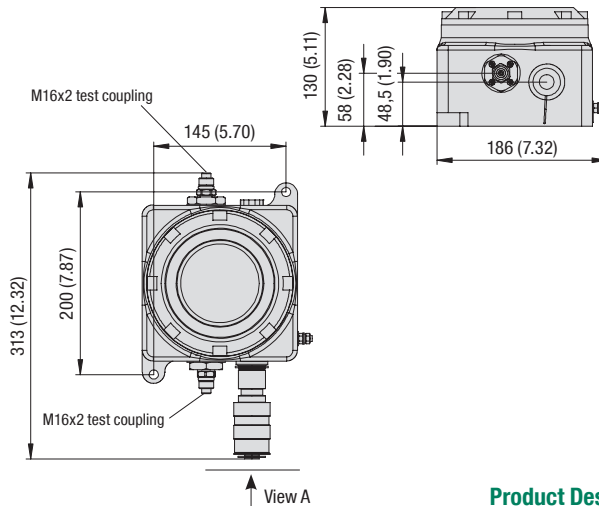

Order Codes

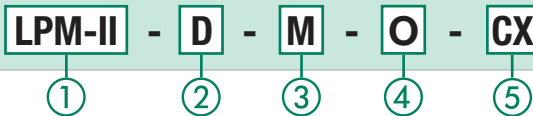

① Series and Type

Particle Monitor **LPM-II**

② Version

With display **D**

③ Fluid Compatibility

Fluids based on Mineral Oil and Petroleum (standard) **M**
 Phosphate Ester (e.g. Skydrol®) **E**
 Specific Water Glycols **G**

Note: If you have any queries on fluid compatibility, please contact STAUFF.

④ Moisture Sensor / Temperature Sensor

Without moisture sensor / temperature sensor **O**
 With moisture sensor / temperature sensor **W**

⑤ Version according to ATEX 94/9/EG

ATEX certification (Zone 2 / Cat. 3G) **CX**

Note: Versions „E“ and „G“ can not be supplied with moisture sensor / temperature sensor.

Note: You need an interface module with either USB or an ethernet interface for exporting and programming. The USB interface is not ATEX rated.

Product Description

The ATEX version of the Particle Monitor LPM-II is approved for use in hazardous areas (zone 2 / category 3G). The device thus meets the conditions to be used in e.g. oil and gas industry or chemical and process industry.

Product Features

- Determines contamination level of measured fluids in 8 size particle channels
- Precise and complete determination of particle sizes in accordance with international standards
- Integrated data storage for up to 4000 measuring results
- Integrated Modbus and CAN Bus interfaces can be used to connect the device to existing machine control, and data acquisition systems
- Option to specify different alarm thresholds
- Software on CD (included)
- ATEX certificated (Zone 2 / Category 3G)

Technical Data

Channels

- >4, 6, 14, 21, 25, 38, 50, 70 µm(c) acc. to ISO 4406:1999

Measuring Range / Purity Classes

- ISO 4406:1999 Code 0 to 25, NAS 1638 classes 00 to 12, AS4059 Rev. E. tables 1 and 2 sizes A-F: classes 000 to 12, ISO 11218 classes 00 to 12 (lower codes or classes are test time-dependent)

Accuracy

- ±1/2 code for 4, 6, 14 µm(c)
- ±1 code for larger particles

Calibration

- Each device is individually calibrated using ISO Medium Test Dust (MTD) in accordance with ISO 11171 (1999)

Flow

- 20 ... 400 ml/min / .00511 US GPM

Viscosity Range

- ≤ 1000 mm²/s

Temperature Range

- Media: -25 °C ... +80 °C / -13 °F ... +176 °F
- Ambient: -5 °C ... +80 °C / +23 °F ... +176 °F

Weight

- 5,5 kg / 12.16 lbs

Power Supply

- 9 ... 36 V DC

Fluid Compatibility

- M: suitable for Synthetic and Mineral Oil based fluids, Diesel and Petroleum
- G: Austenitic Stainless Steel, FKM/FPM (Viton®): suitable for offshore and aqueous fluids
- E: Austenitic Stainless Steel, Perfluorinated Rubber (FFKM): suitable for Phosphate Ester and aggressive media

Max. Permissible Operating Pressure

- 400 bar / 5801 PSI (Note: In systems with extreme pressure peaks, please contact STAUFF)

Test Duration

- Settable between 10 ... 3600 sec., set ex-works to 120 sec.
- As standard with start delay and freely programmable test intervals

Moisture Sensor / Temperature Sensor

- % RH (relative humidity) ±3 %
- ±3 °C / ±32 °F

Volumetric Flow Measurement

- As display only

Hose Connections

- Test coupling STAUFF Test 20 or comparable (M16 x 2)

Data Storage

- Max. 4000 measuring results

Interfaces

- RS485, RS232, Modbus, CAN Bus

Current Consumption

- 12 V: 70 mA
- 24 V: 40 mA
- 36 V: 30 mA

Power

- <2,2 W

Housing Surface Treatment

- Polyester vinyl paint (light grey)
- Cast
- Stainless Steel
- Material spec.: ANC ABF/C

Wetted Parts

- M: C46400 Cu Alloy, 316 Stainless Steel, FKM/FPM (Viton®), FR4, Sapphire
- G: 316 Stainless Steel, FKM/FPM (Viton®), Sapphire
- E: 316 Stainless Steel, Perfluorinated Rubber (FFKM), Sapphire, EPDM

ATEX Directive 94/9/EG

Harmonises legal provisions of memberstates for devices and protection systems for designated use in potentially explosive areas.

ATEX Classification

- CE II 3G Ex nR IIB T6 X

ATEX Rating

- Zone 2 / Cat. 3G



Oil Sampling Kit ▪ Type SFSK-1 / -2



C

Product Description

Fluid analysis is a crucial component of any oil management program. Early detection of potential problems can prevent costly repairs and downtime. STAUFF SFSK oil analysis kits provide the tools to take a sample from a STAUFF test coupling or directly from a reservoir or sump.

For this the supplied hose is directly connected to the test coupling with an adaptor and the fluid is filled into the supplied vials.

But there is also the possibility to draw up the sample directly from a tank with the hand pump and fill it into the vial.

This sample set is available in two versions with BSP and NPT test couplings.

Scope of Delivery

- Contains vacuum pump for drawing samples of oil equipment
- 1 m / 3.28 ft hose for insertion into tank
- Two sample bottles
- STAUFF test points and adaptor allows oil sample to be taken from STAUFF Test 20 test points

Components

SFSK-1

- 1x Fluid Sample Pump FSP-38
- 1x Hose adaptor SHA-20-5.5mm
- 1 m / 3.28 ft Push on 1/4" hose
- 1x SMK-20-1/4NPT-V-D-W3
- 1x SMK-20-7/16UNF-V-E-W3
- Sample bottles

SFSK-2

- 1x Fluid Sample Pump FSP-38
- 1x Hose adaptor SHA-20-5.5mm
- 1 m / 3.28 ft Push on 1/4" hose
- 1x SMK-20-G1/4-B-C-W3
- 1x SMK-20-M10x1-B-A-W3
- Sample bottles

Order Codes

SFSK-1

①

① Series and Type

NPT type	SFSK-1
BSP type	SFSK-2





Preventative maintenance and servicing is playing an increasingly relevant role today to guarantee the trouble-free operation of plant and machinery.

With hydraulic and lubricating oil systems, the main focus is on preventative monitoring of their condition and analysis of the fluids used. Apart from the purity of the oils, which can be determined using mobile or stationary STAUFF LasPac-II and LPM-II Laser Particle Counters, oil ageing is a second important criterion for the decisive and comprehensive determination of the condition of a system.

Lubricants and operating media age with progressive use. Old or used oils can sometimes no longer guarantee the necessary protection of system components from wear, a factor that can decisively impair the operation of sensitive components in particular. Quite often this means repairing or replacing the affected components, which usually results in expensive downtimes and unplanned oil changes.

The STAUFF OCS Oil Condition Sensor continuously monitors the condition of hydraulic and lubricating oils and displays this in real time on the OCD Oil Condition Display, optionally available as an accessory.

The OCD displays the values recorded by the OCS sensor on a multi-segment display, which enables the oil condition and temperature to be recorded at a glance without the need to connect to a PC.

The data can, of course, also be transmitted directly into the machine control or to a PC, if required. More important, a multi-coloured LED provides the ACTUAL condition in relation to the TARGET condition, which enables demand-led maintenance and oil change intervals to be planned.



Oil Condition Sensor - Type OCS-I-M-B08-M16

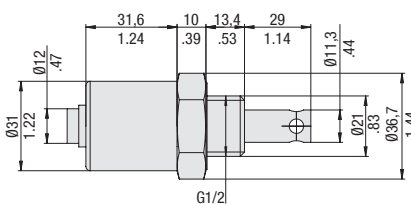

Product Description

The Oil Condition Sensor OCS is designed for continuous monitoring of hydraulic systems. Permanently installed in the system the OCS sensor monitors the condition of hydraulic fluids and lubricating oils in real time, whereby water ingress and oxidation can be detected in time. The OCS sensor is 60 times more sensitive than dielectric sensors on increasing contamination and protects the system from cost-intensive downtimes and reduces machine downtimes.

Technical Data

Materials

- Stainless Steel (corrosion-resistant Steel) AISI304, 1.4301

Dimensions

- 90 x 37 mm / 3.54 x 1.46 in

Weight

- 160 g / .35 lbs

Sealing Material

- FKM/FPM (Viton®)

Features

- Robust construction
- Usage under extreme conditions with temperatures from -20 °C to +120 °C / -4 °F to +248 °F
- Suitable for use at operating pressures up to 20 bar / 290 PSI

Max. Burst Pressure

- 20 bar / 290 PSI

Media Temperature

- 20 °C ... +120 °C / -4 °F ... +248 °F

Media Compatibility

- Mineral and Synthetic Oil
(Please contact STAUFF for other fluids)

Process Connection

- G1/2

Order Code

OCS-I-M-B08-M16



① Series

Oil Condition Sensor (only) **OCS-I-M-B08-M16**

Electrical Connection

- 6-pin connection plug

Power Supply

- 9 ... 30 V DC

Analog Output

- 4 ... 20 mA

Computer Interface

- RS485

Protection Rating

- IP67

USB Interface - Type Interface-OCS-I-USB

Product Description

The OCS sensor respectively the Display-OCS-I can be connected to a PC or laptop using the Interface-OCS-I-USB. It allows you to download the measured data and to carry out programming using the supplied software.

The Interface-OCS-I-USB was not designed for a permanent operating and should be used for programming the OCS sensor respectively download the measured data from the Display-OCS-I only.

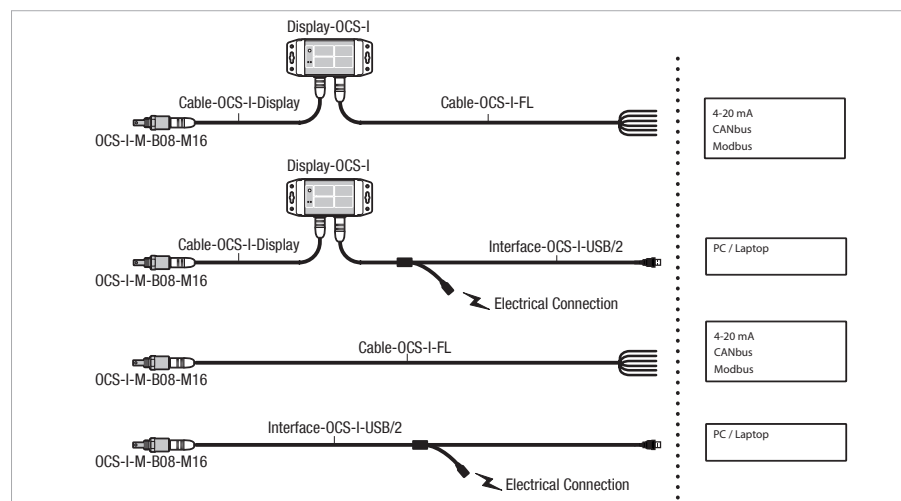

Order Code

Cable-OCS-I-Display



① Series

Connection Cable **Cable-OCS-I-Display**

Order Code

Interface-OCS-I-USB/2



① Series

Connection Cable **Interface-OCS-I-USB/2**

Order Code

Cable-OCS-I-FL



① Series

Connection Cable **Cable-OCS-I-FL**



Oil Condition Display ■ Type Display-OCS-I

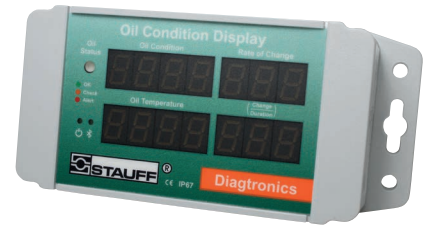
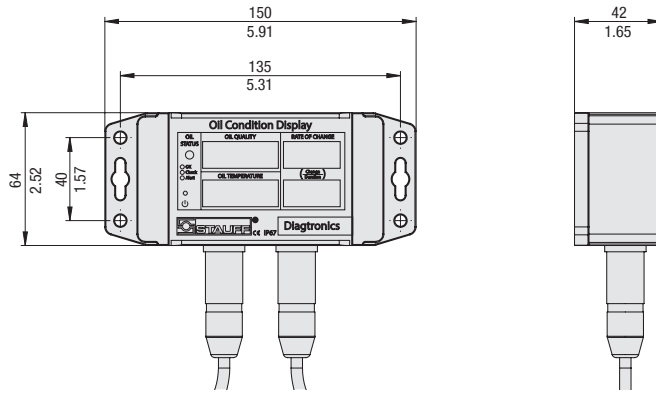

C

Order Code

Display-OCS-I



① Series

Oil Condition Display OCS **Display-OCS-I**

Product Description

The optional Oil Condition Display OCS unit shows the values measured by the sensor using a multi-segment LED indicator, which makes the oil condition apparent at a glance and without any connection to a PC.

The display unit also has integrated measurement value memory, from which the data can be subsequently transferred for assessment via USB.

Technical Data

Materials

- Polycarbonate

Dimensions

150 x 64 x 42 mm / 5.91 x 2.52 x 1.65 in

Weight

- 250 g / .35 lbs

Power Supply

- 9 ... 30 V DC

Analog Output

- 4 ... 20 mA

Computer Interface

- RS485, 9600 Baud (half duplex)

Mounting

- Mounting flange on back side
150 x 64 mm / 5.91 x 2.52 in

Protection Rating

- IP67

Display

- Multi-segment LED indicator
(20 segments: 13 green LED, 4 amber LED, 3 red LED, 1 red LED (Unit ON))

Order Code

Starterkit-OCS-I



① Series

Starterkit **Starterkit-OCS-I**

Includes

- 1x Oil Condition Sensor - Type OCS-I-M-B08-M16
- 1x Oil Condition Display - Type Display-OCS-I
- 1x Connection Cable - Type Cable-OCS-I-Display
- 1x Connection Cable - Type Interface-OCS-I-USB/2
- 1x Connection Cable - Type Cable-OCS-I-FL

Starterkit ■ Type Starterkit-OCS-I

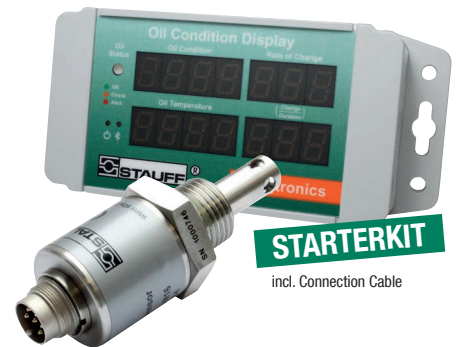

incl. Connection Cable



SMFS-P-015



SMFS-U-030



SMFS-U-DL-015-G



SMFS-U-060



SMFS-U-110



SMFS-U-CM-110







STAUFF Filtration Technology offers a complete range of filtration products and services. This will provide the system designer or user with the highest level of contamination control demanded by today's most sophisticated applications.

STAUFF Filtration Technology Products include Pressure Filters, Return Line Filters, Replacement Filter Elements, Spin-On Filters, Suction Strainers and Filter Breathers for various hydraulic, lubrication and fuel oils.

STAUFF has the technical expertise to provide superior filter element designs for the STAUFF original filter housings and also for the interchange element market.

STAUFF manufactures more than 10000 different elements. Many of these are designed to fit into filter housings produced by other companies while maintaining or surpassing the original performance.

A well-stocked warehouse guarantees the possibility of short-term arrangements without their own storage. Therefore, we can react flexible for your specific needs.

The "STAUFF Contamination Control Program" comprised the diagnostic services including fluid sampling and laser particle counting products for monitoring the system contamination level. In addition STAUFF offers a range of software solutions for element interchange and filter calculation. All products are subject to the audits in reference to international standards. This ensures a consistently high standard of quality.



Please do not hesitate to contact STAUFF for further details.

www.stauff.com
www.filterinterchange.com



Index

Mobile Filtration System - Type SMFS-P-015	
Product Description / Technical Data	6
Dimensions / Order Codes	7
Filter Elements - Type SFC-35/36	7
Mobile Filtration System - Type SMFS-U-030	
Product Description / Technical Data	8
Dimensions / Order Codes	9
Filter Elements - Type SFC-57/58	9
Mobile Filtration System - Type SMFS-U-DL-015-G	
Product Description / Technical Data	10
Dimensions / Order Codes	11
Filter Elements - Type SFC-57/58	11
Mobile Filtration Systems - Types SMFS-U-060 / -110	
Product Description / Technical Data	12
Dimensions / Order Codes	13
Filter Elements - Type NR-630	13
Mobile Filtration System - Type SMFS-U-CM-110	
Product Description / Technical Data	14
Dimensions / Order Codes	15
Filter Elements - Type NR-630	15

			
Type	SMFS-P-015	SMFS-U-030	SMFS-U-DL-015-G
Flow	15 l/min / 4 US GPM (depends on the viscosity of fluid)	30 l/min / 7.5 US GPM (depends on the viscosity of fluid)	15 l/min / 4 US GPM (depends on the viscosity of fluid)
Pump	Gear pump	Gear pump	Gear pump
Motors	0,75 kW; 1400 U/min	0,75 kW; 1400 U/min	0,75 kW; 1400 U/min
Electrical Connection	230 V AC @ 50 Hz - 1 phase Safety Plug 400 V AC @ 50 Hz - 3 phases Plug CEE 16A 3P+N+PE IP 55 protection rating	230 V AC @ 50 Hz - 1 phase Safety Plug 400 V AC @ 50 Hz - 3 phases Plug CEE 16A 3P+N+PE IP 55 protection rating	230 V AC @ 50 Hz - 1 phase Safety Plug 400 V AC @ 50 Hz - 3 phases Plug CEE 16A 3P+N+PE IP 55 protection rating
Filter Element	SFC-35/36	SFC-57/58	SFC-57/58
Micron Rating	3-125 µm	3-125 µm	3-125 µm
Media Compatibility	mineral oils	mineral oils	mineral oils
Clogging Indicator	STAUFF Visual Pressure Clogging SPG-040	STAUFF Visual Pressure Clogging SPG-040	STAUFF Visual Pressure Clogging SPG-040
Hoses Length Suction Side Pressure Side	1,5 m / 4.92 ft 2 m / 6.56 ft	3 m / 9.84 ft 3 m / 9.84 ft	1,5 m / 4.92 ft 6 m / 19.68 ft
Particle Counter	-	-	-



			
Type	SMFS-U-060	SMFS-U-110	SMFS-U-CM-110
Flow	60 l/min / 15 US GPM (depends on the viscosity of fluid)	110 l/min / 30 US GPM (depends on the viscosity of fluid)	110 l/min / 30 US GPM (depends on the viscosity of fluid)
Pump	Gear pump with pressure limitation valve	Gear pump with pressure limitation valve	Gear pump with pressure limitation valve
Motors	2,2 kW; 1440 U/min	4 kW; 1445 U/min	4 kW; 1445 U/min
Electrical Connection	- 400 V AC @ 50 Hz - 3 phases Plug CEE 16A 3P+N+PE IP 55 protection rating	- 400 V AC @ 50 Hz - 3 phases Plug CEE 16A 3P+N+PE IP 55 protection rating	- 400 V AC @ 50 Hz - 3 phases Plug CEE 16A 3P+N+PE IP 55 protection rating
Filter Element	NR-630	NR-630	NR-630
Micron Rating	3-25 µm	3-25 µm	3-25 µm
Media Compatibility	mineral oils	mineral oils	mineral oils
Clogging Indicator	STAUFF Visual Pressure Clogging HI-A	STAUFF Visual Pressure Clogging HI-A	STAUFF Visual Pressure Clogging HI-E
Hoses Length Suction Side Pressure Side	3 m / 9.84 ft 3 m / 9.84 ft	3 m / 9.84 ft 3 m / 9.84 ft	3 m / 9.84 ft 3 m / 9.84 ft
Particle Counter	-	-	STAUFF Particle Monitor LPM-II



Mobile Filtration System ■ Type SMFS-P-015



Product Description

The SMFS-P-015 supplement the range of STAUFF products, which is a portable hand-held Mobile Filtration System. Due to it's compact and robust design, it can be used very flexible and consistently provides best filtration performance at the same time.

Technical Data

Dimensions and Weight

- W x D x H: 258 x 454 x 551 mm / 10.16 x 17.87 x 21.69 in
- Weight: 33 kg / 51 lbs

Media Compatibility

- Suitable for mineral oils, other fluids on request

Flow

- 15 l/min / 4 US GPM (depends on the viscosity of fluid)

Temperature

- Media temp.: -15 °C ... +65 °C / +5 °F ... +149 °F
- Ambient temp.: -40 °C ... +70 °C / +32 °F ... +158 °F

Viscosity

- Admissible: 10 ... 400 mm²/sec / 10 ... 400 cSt
- Recommended: 25 mm²/sec / 25 cSt

Pressure

- Operating Pressure: 2 bar / 29 PSI
- Pressure for shut-off of the electric motor: 3,5 bar / 51 PSI
- Test pressure: 12 bar / 174 PSI

Framework

- Material: painted Steel (RAL 6026)

Hoses

- Material: PVC, reinforced with internal wire wrapping
- Length: 1,5 m / 4.92 ft on the suction side and 2 m / 6.56 ft on the pressure side
- Dimensions
 - on suction side: DN 25
 - on pressure side: DN 16
- On suction side with integrated coarse filter (Stainless Steel sieve 200 µm)

Lance

- Length 150 mm / 5.91 in

Pump

- Gear pump

Motors

- 230 V: CE-certified motor unit (230 V AC @ 50 Hz - 1 phase) with safety plug (0,75 kW; 1400 U/min)
- 400 V: CE-certified motor unit (400 V AC @ 50 Hz - 3 phases) with plug CEE 16A 3P+N+PE (0,75 kW; 1400 U/min)
- IP 55 protection rating: Dust protected and protected against water jets

Clogging Indicator

- Visual Pressure Clogging Indicator Type SIM 04

Options and Accessories

Replacement Filter Elements

- Filter Elements of the Spin-On series SFC-35/36
- Micron rating available from 3 ... 125 µm
- Also available with a blank filter element (SFC-3500) for the reason of used oil to be removed from the hydraulic reservoir

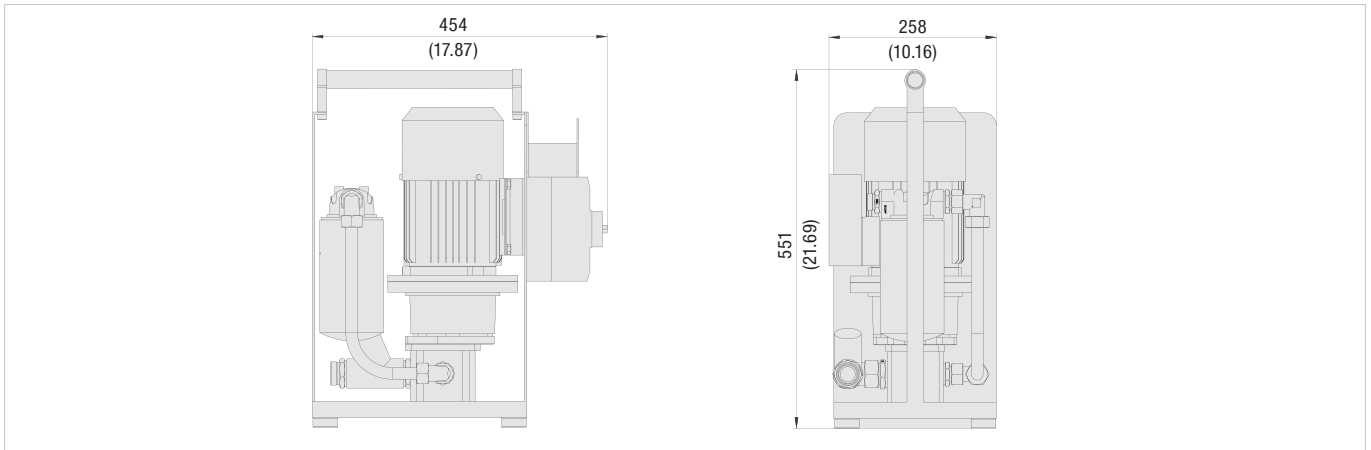
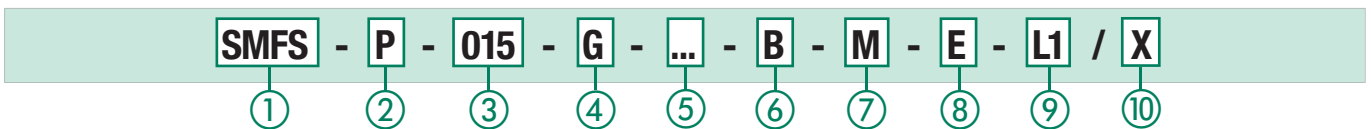

Mobile Filtration System ■ Type SMFS-P-015
Dimensions

Order Codes

① Series

Mobile Filtration System	SMFS
--------------------------	-------------

② Type

Portable unit	P
---------------	----------

③ Flow

15 l/min / 4 US GPM	015
---------------------	------------

④ Pump

Gear pump	G
-----------	----------

⑤ Filter Elements SFC...

Filter element is not included	...
Please order separately - see below!	

⑥ Sealing Material

NBR (Buna-N®)	B
Other sealing materials on request.	

⑦ Clogging Indicator

Visual Pressure Clogging Indicator SIM 04	M
---	----------

⑧ Motor Configuration

230 V / 50 Hz / 1 phase (standard)	E
400 V / 50 Hz / 3 phases	F

⑨ Lance

Length 150 mm / 5.9 in	L1
------------------------	-----------

⑩ Design Code

Only for information	X
----------------------	----------

Filter Elements ■ Type SFC-35/36
Product Description

STAUFF Replacement Filter Elements SFC-35/36 for use with STAUFF Mobile Filtration System SMFS-P-015. For further information and technical data on Replacement Filter Elements please see our product catalogue 9, – STAUFF Filtration Technology.

Order Codes

① Series

Filter Element Series	SFC
-----------------------	------------

② Filter Elements

Filter Elements	Length (mm/in)	Code
Blank filter element		3500
Inorganic Glass Fibre 3 µm 145 / 5.7		3503AE
Inorganic Glass Fibre 3 µm 190 / 7.5		3603AE
Inorganic Glass Fibre 10 µm 145 / 5.7		3510AE
Inorganic Glass Fibre 10 µm 190 / 7.5		3610AE
Wire Mesh 60 µm 145 / 5.7		3560E
Wire Mesh 60 µm 190 / 7.5		3660E
Brass Mesh 125 µm 145 / 5.7		35125E
Brass Mesh 125 µm 190 / 7.5		36125E



Dimensional drawings: All dimensions in mm/in.

Mobile Filtration System ■ Type SMFS-U-030



Product Description

The SMFS-U-030 is a Mobile Filtration System mounted on a robust steel frame push cart, which means the perfect compromise between flexibility on the one hand and highest nominal flow rates on the other hand.

Technical Data

Dimensions and Weight

- W x D x H: 570 x 650 x 1230 mm / 22.44 x 25.59 x 48.43 in
- Weight: 58,5 kg / 129 lbs

Media Compatibility

- Suitable for mineral oils, other fluids on request

Flow

- 30 l/min / 7.5 US GPM (depends on the viscosity of fluid)

Temperature

- Media temp.: -15 °C ... +65 °C / +5 °F ... +149 °F
- Ambient temp.: -40 °C ... +70 °C / +32 °F ... +158 °F

Viscosity

- Admissible: 10 ... 400 mm²/sec / 10 ... 400 cSt
- Recommended: 25 mm²/sec / 25 cSt

Pressure

- Operating pressure: 2 bar / 29 PSI
- Pressure for shut-off of the electric motor: 3,5 bar / 51 PSI
- Test pressure: 12 bar / 174 PSI

Framework

- Material: painted Steel (RAL 6026)
- Removable oil sump

Hoses

- Material: PVC, reinforced with internal wire wrapping
- Length: 2 x 3 m / 9.84 ft on the suction and pressure side
- Dimensions
 - on suction side: DN 16
 - on pressure side: DN 13
- On suction side with integrated coarse filter (Stainless Steel sieve 200 µm)

Lance

- Length 450 mm / 17.72 in

Pump

- Gear pump

Motors

- 230 V: CE-certified motor unit (230 V AC @ 50 Hz - 1 phase) with safety plug (0,75 kW; 1400 U/min)
- 400 V: CE-certified motor unit (400 V AC @ 50 Hz - 3 phases) with plug CEE 16A 3P+N+PE (0,75 kW; 1400 U/min)
- IP 55 protection rating: Dust protected and protected against water jets

Clogging Indicator

- Visual Pressure Clogging Indicator Type SIM 04

Options and Accessories

Replacement Filter Elements

- Filter Elements of the Spin-On series SFC-57/58
- Micron rating available from 3 ... 125 µm
- Also available with a blank filter element (SFC-5700) for the reason of used oil to be removed from the hydraulic reservoir

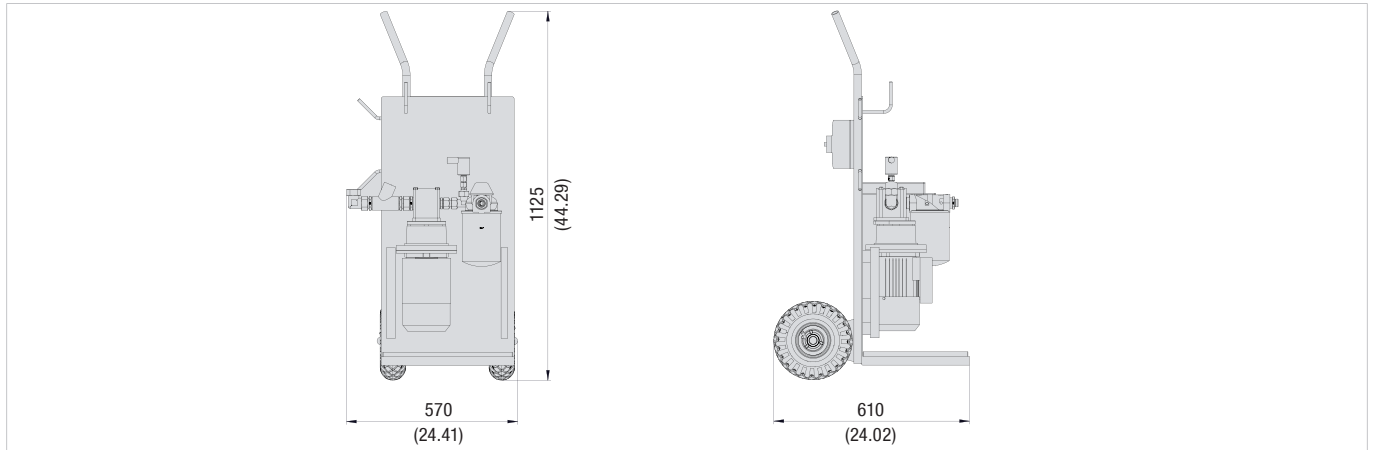
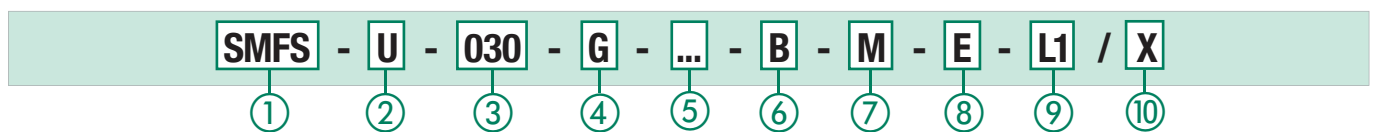

Mobile Filtration System ■ Type SMFS-U-030
Dimensions

Order Codes

① Series

Mobile Filtration System	SMFS
--------------------------	-------------

② Type

Mobile unit	U
-------------	----------

③ Flow

30 l/min / 7.5 US GPM	030
-----------------------	------------

④ Pump

Gear pump	G
-----------	----------

⑤ Filter Elements SFC...

Filter element is not included	...
Please order separately - see below!	

⑥ Sealing Material

NBR (Buna-N®)	B
Other sealing materials on request.	

⑦ Clogging Indicator

Visual Pressure Clogging Indicator SIM 04	M
---	----------

⑧ Motor Configuration

230 V / 50 HZ / 1 phase (standard)	E
400 V / 50 HZ / 3 phases	F

⑨ Lance

Length 450 mm / 17.72 in	L1
--------------------------	-----------

⑩ Design Code

Only for information	X
----------------------	----------

Filter Elements ■ Type SFC-57/58
Product Description

STAUFF Replacement Filter Elements SFC-57/58 for use with STAUFF Mobile Filtration System SMFS-U-030. For further information and technical data on Replacement Filter Elements please see our product catalogue 9, – STAUFF Filtration Technology.

Order Codes

① Series

Filter Element Series	SFC
-----------------------	------------

② Filter Elements

Filter Elements	Length (mm/in)	Code
Blank filter element		5700
Inorganic Glass Fibre 3 µm	180 / 7.1	5703AE
Inorganic Glass Fibre 3 µm	226 / 8.9	5803AE
Inorganic Glass Fibre 10 µm	180 / 7.1	5710AE
Inorganic Glass Fibre 10 µm	226 / 8.9	5810AE
Wire Mesh 60 µm	180 / 7.1	5760E
Wire Mesh 60 µm	226 / 8.9	5860E
Brass Mesh 125 µm	180 / 7.1	57125E
Brass Mesh 125 µm	226 / 8.9	58125E



Dimensional drawings: All dimensions in mm/in.



Mobile Filtration System ■ Type SMFS-U-DL-015-G



Product Description

The SMFS-U-DL-015-G is the first unit that has the filtration components including a high-quality motor/pump unit used along with a sturdy transport cart for 200l / 52 US GAL oil drums with a weight up to 250 kg / 551 lbs.

Technical Data

Dimensions and Weight

- W x D x H: 1000 x 1100 x 1200 mm / 39.37 x 43.30 x 47.24 in
- Weight: 85 kg / 187 lbs

Media Compatibility

- Suitable for mineral oils, other fluids on request

Flow

- 15 l/min / 4 US GPM (depends on the viscosity of fluid)

Temperature

- Media temp.: -15 °C ... +65 °C / +5 °F ... +149 °F
- Ambient temp.: -40 °C ... +70 °C / +32 °F ... +158 °F

Viscosity

- Admissible: 10 ... 400 mm²/sec / 10 ... 400 cSt
- Recommended: 25 mm²/sec / 25 cSt

Pressure

- Operating pressure: 4,5 bar / 65 PSI (Oil Pump Nozzle open)
- Pressure for shut-off of the Pump: 8 bar / 116 PSI (Oil Pump Nozzle closed)
- Test pressure: 12 bar / 174 PSI

Framework

- Material: painted Steel (RAL 6026)

Hoses

- Material
 - Suction Side: PVC, reinforced with internal wire wrapping
 - Pressure Side: Synthetic rubber with Textile braid
- Length: 1,5 m / 4.92 ft on the suction side and 6 m / 19.68 ft on the pressure side
- Dimensions
 - on suction side: DN 25
 - on pressure side: DN 16
- On suction side with integrated coarse filter (Stainless Steel sieve 200 µm)

Lance

- Length 300 mm / 11.81 in

Pump

- Gear pump

Motors

- 230 V: CE-certified motor unit (230 V AC @ 50 Hz - 1 phase) with safety plug (0,75 kW; 1400 U/min)
- 400 V: CE-certified motor unit (400 V AC @ 50 Hz - 3 phases) with plug CEE 16A 3P+N+PE (0,75 kW; 1400 U/min)
- IP 55 protection rating: Dust protected and protected against water jets

Clogging Indicator

- Visual Pressure Clogging Indicator Type SPG-040

Options and Accessories

Replacement Filter Elements

- Filter Elements of the Spin-On series SFC-57/58
- Micron rating available from 3 ... 125 µm
- Also available with a blank filter element (SFC-5700) for the reason of used oil to be removed from the hydraulic reservoir

Ölfass nicht im Lieferumfang enthalten.

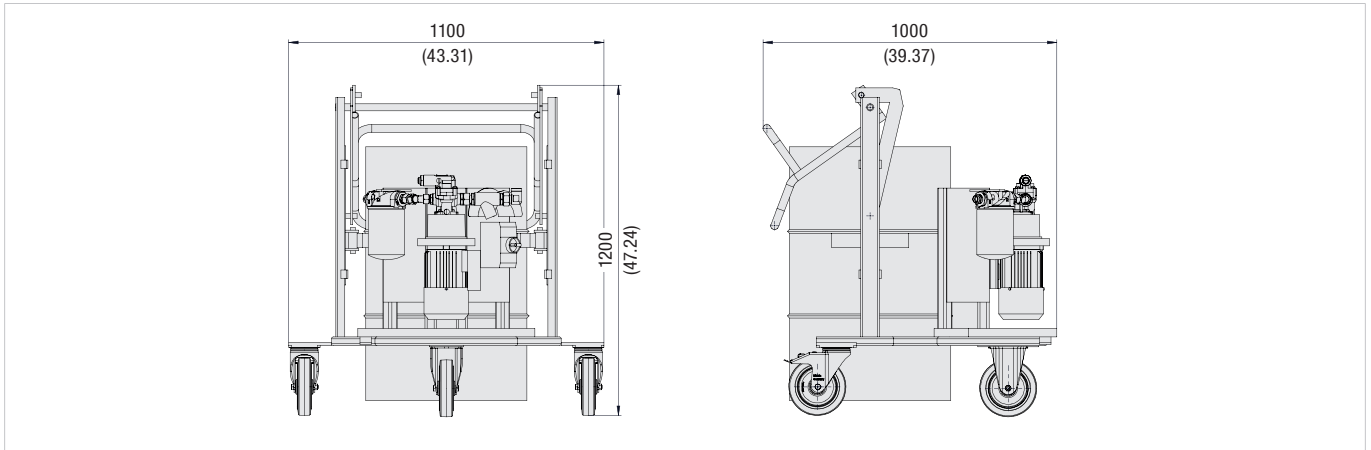

Mobile Filtration System ■ Type SMFS-U-DL-015-G
Dimensions

Order Codes

SMFS - U - DL - 015 - G - ... - B - G / X

1
 2
 3
 4
 5
 6
 7
 8
 9

① Series

Mobile Filtration System **SMFS**

② Type

Mobile unit **U**

③ Drum Lift

with Drum Lift **DL**

④ Flow

15 l/min / 4 US GPM **015**

⑤ Pump

Gear pump **G**

⑥ Filter Elements SFC...

Filter element is not included
Please order separately - see below! **...**

⑦ Sealing Material

NBR (Buna-N®) **B**
Other sealing materials on request.

⑧ Motor Configuration

230 V / 50 HZ / 1 phase **G**
400 V / 50 HZ / 3 phases **D**

⑨ Design Code

Only for information **X**

Filter Elements ■ Type SFC-57/58
Product Description

STAUFF Replacement Filter Elements SFC-57/58 for use with STAUFF Mobile Filtration System SMFS-U-DL-015-G. For further information and technical data on Replacement Filter Elements please see our product catalogue 9, – STAUFF Filtration Technology.

Order Codes

SFC - 5710AE

1
 2

① Series

Filter Element Series **SFC**

② Filter Elements

Filter Elements	Length (mm/in)	Code
Blank filter element		5700
Inorganic Glass Fibre 3 µm	180 / 7.1	5703AE
Inorganic Glass Fibre 3 µm	226 / 8.9	5803AE
Inorganic Glass Fibre 10 µm	180 / 7.1	5710AE
Inorganic Glass Fibre 10 µm	226 / 8.9	5810AE
Wire Mesh 60 µm	180 / 7.1	5760E
Wire Mesh 60 µm	226 / 8.9	5860E
Brass Mesh 125 µm	180 / 7.1	57125E
Brass Mesh 125 µm	226 / 8.9	58125E

Dimensional drawings: All dimensions in mm/in.



Mobile Filtration Systems ▪ Types SMFS-U-060 / -110



SMFS-U-060



SMFS-U-110

Product Description

STAUFF manufactures a complete range of Mobile Filtration Systems. Compact in design and easy to operate on the one hand, but also made for permanent use with high flow rates on the other hand, Mobile Filtration Systems are essential tools for the preventive maintenance either to transfer new oil or to purify hydraulic and lubrication oil systems.

Technical Data

Dimensions and Weight

- W x D x H: 947 x 620 x 984 mm / 37.28 x 24.41 x 38.74 in
- Weight:
 - SMFS-U-060: 165 kg / 364 lbs
 - SMFS-U-110: 177,2 kg / 391 lbs

Media Compatibility

- Suitable for mineral oils, other fluids on request

Flow

- SMFS-U-060: 60 l/min / 15 GPM (depends on the viscosity of fluid)
- SMFS-U-110: 110 l/min / 30 GPM (depends on the viscosity of fluid)

Temperature

- Media temp.: -15 °C ... +65 °C / +5 °F ... +149 °F
- Ambient temp.: -40 °C ... +70 °C / +32 °F ... +158 °F

Viscosity

- Admissible: 12 ... 800 mm²/sec / 12...800 cSt
- Recommended (at continuous exposure): 20 ... 100 mm²/sec / 20...100 cSt

Pressure

- Operating pressure: max. 4 bar / max. 58 PSI
- Suction pressure: max. -0,4 bar / max. -6 PSI
- Pressure for shut-off of the electric motor: over pressure of 7 bar / 101 PSI
- Burst pressure
 - on suction side: 11 bar / 160 PSI
 - on pressure side: 15 bar / 218 PSI
- Test pressure: 24 bar / 348 PSI

Framework

- Material: phosphated and epoxy-coated Steel

Hoses

- Material: PVC, reinforced with internal wire wrapping
- Length: 3m / 9.84ft on the suction and pressure side
- Dimensions
 - on suction side: DN 38
 - on pressure side: DN 28

Pump

- Gear pump with pressure limitation valve

Motor

- CE-certified motor unit (400 VAC @ 50 Hz - 3 phases)
- IP 55 protection rating
- Plug CEE 16A 3P+N+PE
- SMFS-U-060: 2,2kW
- SMFS-U-110: 4kW

Options and Accessories

Replacement Filter Elements

- Filter Elements series NR-630
- Micron rating available from 3 ... 25 µm

Clogging Indicator

- Clogging Indicator Type HI-A (Visual, automatic reset)

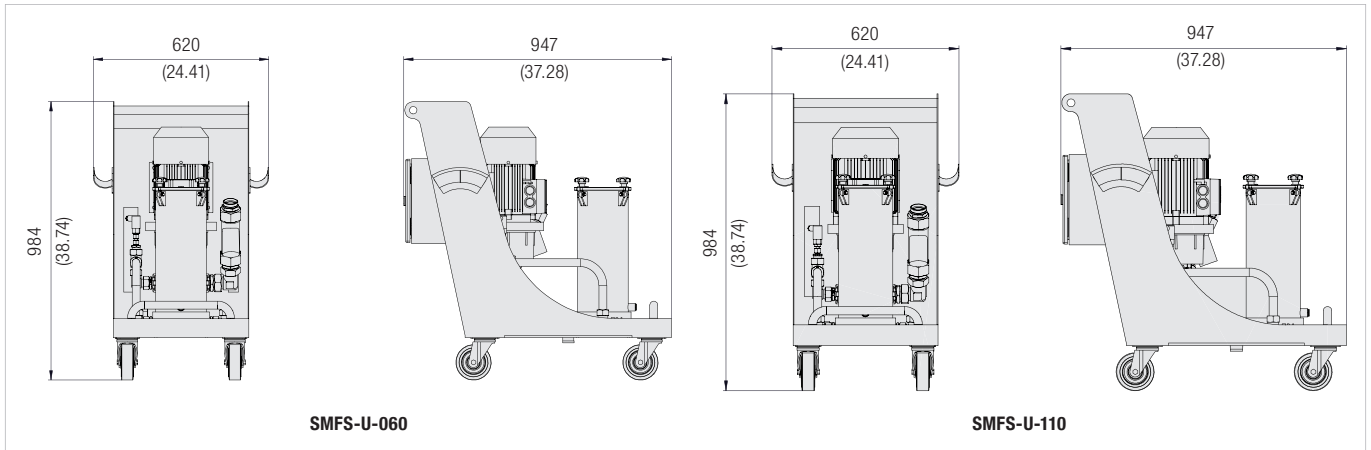

Mobile Filtration Systems ■ Types SMFS-U-060 / -110
Dimensions

Order Codes

SMFS - U - 060 - G - ... - B - A - F - / X

1 2 3 4 5 6 7 8 9

① Series

Mobile Filtration System **SMFS**

② Type

Mobile unit **U**

③ Flow

60 l/min / 15 US GPM **060**
110 l/min / 30 US GPM **110**

④ Pump

Gear pump **G**

⑤ Filter Elements NR-630...

Filter element is not included ...
Please order separately - see below!

⑥ Sealing Material

NBR (Buna-N®) **B**
Other sealing materials on request.

⑦ Clogging Indicator

Visual, automatic reset **A**

⑧ Motor Configuration

400 V / 50 Hz / 3 phases **F**
Other configurations on request.

⑨ Design Code

Only for information **X**

Filter Elements ■ Type NR-630
Product Description

STAUFF Replacement Filter Elements NR-630 for use with STAUFF Mobile Filtration Systems SMFS-U-030 and SMFS-U-110. All STAUFF Inorganic Glass Fibre Filter Elements are designed to achieve β -value ≥ 200 at their rated micron rating. For further information and technical data on Replacement Filter Elements please see our product catalogue 9, – STAUFF Filtration Technology.

Order Codes

NR-630 E10 - B

1 2 3

① Series

Filter Element Series **NR-630**

② Filter Elements

Filter Elements	Code
Inorganic Glass Fibre 3 μ m	E03
Inorganic Glass Fibre 6 μ m	E06
Inorganic Glass Fibre 10 μ m	E10
Inorganic Glass Fibre 16 μ m	E16
Inorganic Glass Fibre 25 μ m	E25

③ Sealing Material

NBR (Buna-N®) **B**
Other sealing materials on request.



Dimensional drawings: All dimensions in mm/in.



Mobile Filtration System ■ Type SMFS-U-CM-110



Product Description

In addition to the mobile filter system SMFS-U-110 the SMFS-U-CM-110 provides a particle counter LPM-II and a control panel to setup the operating mode and display the test results.

Technical Data

Dimensions and Weight

- W x D x H: 947 x 620 x 984 mm / 37.28 x 24.41 x 38.74 in
- Weight: 220 kg / 485 lbs

Media Compatibility

- Suitable for mineral oils, other fluids on request

Flow

- 110 l/min / 30 GPM (depends on the viscosity of fluid)

Temperature

- Media temp.: -15 °C ... +65 °C / +5 °F ... +149 °F
- Ambient temp.: -40 °C ... +70 °C / +32 °F ... +158 °F

Viscosity

- Admissible: 12 ... 800 mm²/sec / 12...800 cSt
- Recommended (at continuous exposure): 20 ... 100 mm²/sec / 20...100 cSt

Pressure

- Operating pressure: max. 4 bar / max. 58 PSI
- Suction pressure: max. -0,4 bar / max. -6 PSI
- Switch off pressure motor protection switch: over pressure of 7 bar / 101 PSI
- Burst pressure
 - on suction side: 11 bar / 160 PSI
 - on pressure side: 15 bar / 218 PSI
- Test pressure: 24 bar / 348 PSI

Framework

- Material: phosphated and epoxy-coated Steel

Hoses

- Material: PVC, reinforced with internal wire wrapping
- Length: 3m / 9.84ft on the suction and pressure side
- Dimensions
 - on suction side: DN 38
 - on pressure side: DN 28

Pump

- Gear pump with pressure limitation valve

Motor

- CE-certified motor unit (400 VAC @ 50 Hz - 3 phases)
- IP 55 protection rating
- Plug CEE 16A 3P+N+PE

Outstanding Features

- 8-channel particle counter incl. moisture / temperature sensor (in a separated control enclosure)
- Software LasPaC II View supports an easy download for data processing of the recorded measurements



- Control panel to setup the operating mode and display the test results/measurements



- Electric Clogging Indicator / Signal „Change Element“ is displayed on the control panel



Options and Accessories

Replacement Filter Elements

- Filter Elements series NR-630
- Micron rating available from 3 ... 25 µm

Clogging Indicator

- Clogging Indicator Type HI-E

Particle Counter

- STAUFF Particle Monitor LPM-II

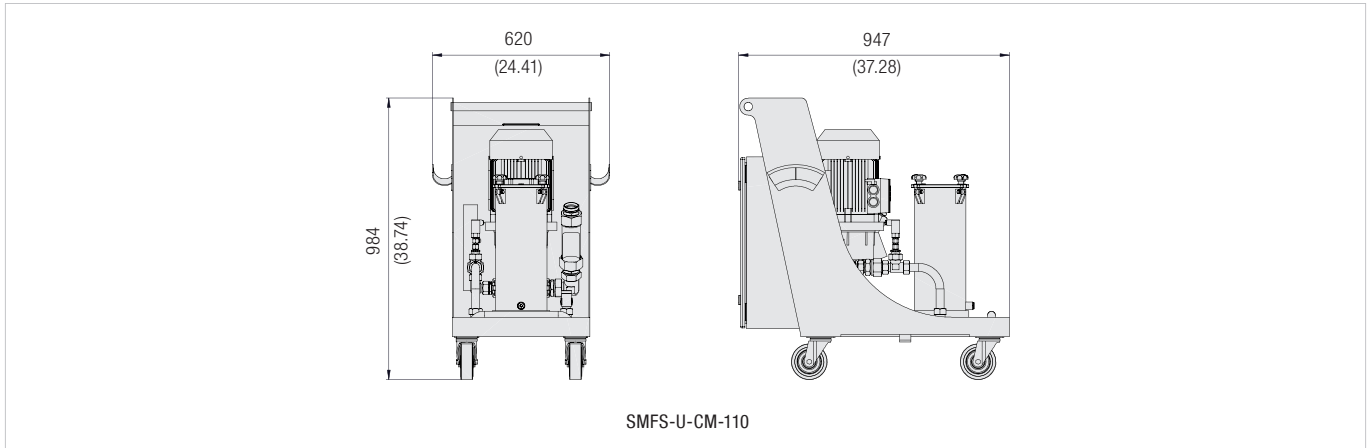

Mobile Filtration System ■ Type SMFS-U-CM-110
Dimensions

Order Codes

SMFS	-	U	-	CM	-	110	-	G	-	...	-	B	-	E	-	F
①		②		③		④		⑤		⑥		⑦		⑧		⑨

① Series Mobile Filtration System SMFS	⑤ Pump Gear pump G	⑧ Clogging Indicator electric E
② Type Mobile unit U	⑥ Filter Elements NR-630... Filter element is not included Please order separately - see below! ...	⑨ Motor Configuration 400 V / 50 HZ / 3 phases F Other configurations on request.
③ Condition Monitoring with Condition Monitoring CM	⑦ Sealing Material NBR (Buna-N®) B Other sealing materials on request.	
④ Flow 110 l/min / 30 US GPM 110		

Filter Elements ■ Type NR-630
Product Description

STAUFF Replacement Filter Elements NR-630 for use with STAUFF Mobile Filtration System SMFS-U-CM-110. All STAUFF Inorganic Glass Fibre Filter Elements are designed to achieve β -value ≥ 200 at their rated micron rating. For further information and technical data on Replacement Filter Elements please see our product catalogue 9, – STAUFF Filtration Technology.

Order Codes

NR-630	-	E10	-	B
①		②		③

① Series Filter Element Series NR-630												
② Filter Elements <table border="1"> <thead> <tr> <th>Filter Elements</th> <th>Code</th> </tr> </thead> <tbody> <tr> <td>Inorganic Glass Fibre 3 μm</td> <td>E03</td> </tr> <tr> <td>Inorganic Glass Fibre 6 μm</td> <td>E06</td> </tr> <tr> <td>Inorganic Glass Fibre 10 μm</td> <td>E10</td> </tr> <tr> <td>Inorganic Glass Fibre 16 μm</td> <td>E16</td> </tr> <tr> <td>Inorganic Glass Fibre 25 μm</td> <td>E25</td> </tr> </tbody> </table>	Filter Elements	Code	Inorganic Glass Fibre 3 μ m	E03	Inorganic Glass Fibre 6 μ m	E06	Inorganic Glass Fibre 10 μ m	E10	Inorganic Glass Fibre 16 μ m	E16	Inorganic Glass Fibre 25 μ m	E25
Filter Elements	Code											
Inorganic Glass Fibre 3 μ m	E03											
Inorganic Glass Fibre 6 μ m	E06											
Inorganic Glass Fibre 10 μ m	E10											
Inorganic Glass Fibre 16 μ m	E16											
Inorganic Glass Fibre 25 μ m	E25											
③ Sealing Material NBR (Buna-N®) B Other sealing materials on request.												



Dimensional drawings: All dimensions in mm/in.