

rotork®

Group Product Portfolio



Keeping the World Flowing

rotork®

Keeping the World Flowing



**RELIABILITY
IN FLOW CONTROL
CRITICAL
APPLICATIONS**



RELIABLE OPERATION WHEN IT MATTERS

Assured reliability for critical applications and environments. Whether used 24/7 or infrequently, Rotork products will operate reliably and efficiently when called upon.

QUALITY-DRIVEN GLOBAL MANUFACTURING

Products designed with 60 years of industry and application knowledge.

Research and development across all our facilities ensures cutting edge products are available for every application.

CUSTOMER-FOCUSED SERVICE WORLDWIDE SUPPORT

Solving customer challenges and developing new solutions. From initial enquiry through to product installation, long-term after-sales care and Client Support Programmes (CSP).

LOW COST OF OWNERSHIP

Long-term reliability prolongs service life.

Rotork helps to reduce long term cost of ownership and provides greater efficiency to process and plant.

Group Product Portfolio

Section	Page	Section	Page
Rotork - Keeping the World Flowing	2	Precision Control and Indication	38
Electric Actuators and Control Systems	8	Network Control Systems	44
Fluid Power Actuators and Control Systems	18	Client Support and Site Services	48
Valve Gear Operators and Accessories	26		



COMPREHENSIVE PRODUCT RANGE SERVING MULTIPLE INDUSTRIES

Improved efficiency, assured safety and environmental protection.

Rotork products and services are used in the Power, Oil & Gas, Water & Wastewater, HVAC, Marine, Mining, Food & Beverage, Pharmaceutical and Chemical industries around the world.

GLOBAL PRESENCE LOCAL SERVICE

Global company with local support.

Manufacturing sites, offices and *Centres of Excellence* throughout the world provide unrivalled customer services and fast delivery.

MARKET LEADER TECHNICAL INNOVATOR

The recognised market leader for 60 years.

Our customers have relied upon Rotork for innovative solutions to safely manage the flow of liquids, gases and powders.

CORPORATE SOCIAL RESPONSIBILITY

A responsible business leads to being the best business.

We are socially, ethically, environmentally responsible and committed to embedding CSR across all our processes and ways of working.

rotork®

Keeping the World Flowing



**GLOBAL
EXPERIENCE
STRATEGIC
INDUSTRIES**

Active in every industry and market sector around the world.

Serving customers and working with partners.

Improving efficiency, assuring safety and protecting the environment.

INDUSTRY KNOWLEDGE

Our engineering and application knowledgebase, built over 60 years, allows us to provide innovative and reliable solutions for all flow control applications.

We work across the globe, servicing a diverse range of markets and critical applications.

Our experience of flow control is second to none.



OIL & GAS

Rotork products are used on upstream, midstream and downstream activities, ranging from offshore production facilities, to refining and processing, to transportation, storage and distribution.

- Onshore and offshore production
- Refining and petrochemicals
- Distribution and storage
- Pipelines
- LNG liquefaction and regasification
- Unconventional oil and gas



WATER & WASTEWATER

Rotork products are used on modern state-of-the-art water treatment and distribution processes, which maximise existing resources such as, desalination plants and water re-use projects, together with conventional water and wastewater plants.

- Sludge and sewage treatment
- Water treatment, desalination and re-use
- Environmental control
- Dams, reservoirs and irrigation



POWER

Rotork products are found in traditional power stations, including nuclear power stations where its products are certified for use both inside and outside containment. They are also used for renewable energy generation systems such as thermal solar plants, and emission reduction processes such as flue gas desulphurisation.

- Conventional fuels
- Nuclear energy
- Concentrating solar power
- Geothermal and other renewables



OTHER INDUSTRIES

- Marine
- Pharmaceutical
- HVAC
- Mining
- Biomedical
- Rail
- Paper & Pulp
- Food & Beverage

rotork®

Keeping the World Flowing

**ESTABLISHED
REPUTATION**
**GLOBAL
SUPPORT**

Unrivalled global network of manufacturing sites, service centres, offices and agents.

Tailored support programmes increase plant efficiency.



CUSTOMER FOCUSED

Customers can source Rotork products locally in the knowledge that they will be supported by life-of-plant maintenance, repairs and upgrade services wherever they are in the world, with over 400 service engineers available globally to provide support.

We are committed to close customer ties, with our global network supporting operations in some of the most remote and challenging environments.

We understand the importance of being close to our customers and understanding their needs – this is key to driving innovation.



GLOBAL NETWORK

Rotork operates a truly global network of sales offices with manufacturing plants sited in Europe, Asia and North America. We are proud to be delivering the best solutions everywhere we work.

Rotork has more than 3,700 employees around the world who are fundamental to maintaining our reputation for excellence in innovation and the quality of our products and services.

CLIENT SUPPORT

As an international business, supporting clients wherever their operations and project installations are located is part of our culture.

Rotork's worldwide international sales network allows us to support our clients wherever they are based.

In addition to manufacturing sites throughout the world, Rotork has regional *Centres of Excellence* providing local service and support.

Electric Actuators and Control Systems

rotork® Controls

Rotork Controls products include the group's electric actuator range and network control systems.

Rotork Controls has world class manufacturing facilities, with global locations including UK, USA, Germany, China, Malaysia and India.

Rotork Controls delivers state of the art cutting edge products to the valve industry including:

- Intelligent multi-turn and part-turn valve actuators
- Part-turn / rotary and linear control valve actuators
- Specialist products for HVAC, power station and pump metering applications
- Explosionproof actuators, sensors, switches and controls
- Network control systems

Research and Development

Rotork continually researches new technologies and develops innovative and industry leading products.

We have dedicated research and development centres around the world that all work together to produce the strongest line of valve actuation products available on the market today.

Testing and Quality Assurance

Rotork Controls is recognised for being quality driven and committed to providing our customers with robust and reliable products that meet or exceed their expectations.

We have test facilities located at all of our manufacturing centres. Every product is tested and qualified before shipment to the customer. Our products are manufactured to comply with stringent quality standards around the world.

All Rotork products are designed and manufactured in accordance with ISO 9001, achieving the highest levels of performance and reliability.

Customer Service - the Rotork Advantage

Rotork Controls provides unparalleled world-class service and support locally to you, wherever you are in the world.

Proud to be recognised as the leader in automation products for challenging critical applications.

Unrivalled record of reliability and assured operation in the harshest environments.



Intelligent Integral Non-Intrusive Electric Actuators

IQ range



IQ multi-turn and part-turn electric actuators for arduous environments

Unrivalled industry leading reliability

- Continuous position tracking at all times, even without power
- On power loss, graphical interface, remote indication and datalogger are maintained and accessible
- Extended life and mounting in any orientation with oil bath lubrication
- Water ingress protection, not reliant on terminal cover or cable gland sealing – double-sealed to IP66/68 20m for 10 days
- Built-in protection by using independent torque and position sensing
- Safe, motor-independent, handwheel operation available at all times
- Explosionproof and certified for safety applications (SIL2/3)
- Drive bush bearings sealed for life – no maintenance required

Simple, secure commissioning and configuration

- Rapid and secure commissioning and configuration even without power via multilingual HMI display
- Non-intrusive setting in any environmental conditions – no cover removal required, using Rotork *Bluetooth*® intrinsically safe setting tool
- Easy installation and valve maintenance using detachable thrust bases
- Duplicate operation, configuration and commissioning up to 100 m from actuator with Remote Hand Station (RHS)
- Auto set up function on part-turn variants

Asset management and preventative maintenance

- Real-time valve and actuator performance information viewable on screen
- Safe and secure data download via non-intrusive and intrinsically safe setting tool
- Field upgradeable and configurable control and indication options using setting tool
- Compatible with *Pakscan* P4 digital control and monitoring system plus all leading field bus networks
- Detailed trend analysis, diagnostics and datalogger available, on-screen, downloadable and via *Pakscan*™ Plus network

IQ Range performance data

- Multi-turn direct drive: 14 to 3,000 Nm (10 to 2,200 lbf.ft)
- Multi-turn with IS or IB gearbox: up to 43,000 Nm (31,715 lbf.ft)
- Part-turn direct drive: 20 to 3,000 Nm (14.8 to 2,200 lbf.ft)
- Part-turn with IW gearbox: up to 1,000,000 Nm (737,561 lbf.ft)
- Linear thrust range with linear output: up to 86 kN (19,333 lbf)

Power supply options

- Single-phase, 3-phase or DC supplies

IQ RHS



IQ Remote Hand Station

The Remote Hand Station enables duplicated operation, interrogation and configuration of the latest IQ actuators. For use when the actuator is located in a hazardous or inaccessible location.

- Installation using standard data cable, up to 100 m away from the actuator
- Full replication of actuator configuration, control, monitoring and downloadable data
- Powered from the attached actuator, no need for additional power supply

See *PUB002-056* for further details.

Intelligent Integral Non-Intrusive Multi-turn & Linear Electric Actuators



IQ 3-phase

IQ 3-phase electric actuators for isolating, regulating or inching duties (S2 & S3 / Class A & B) of up to 60 starts / hour.

Direct torque output range from 14 to 3,000 Nm (10 to 2,200 lbf.ft). With second stage gearboxes, multi-turn output torque up to 43,000 Nm (31,715 lbf.ft) and quarter-turn up to 1,000,000 Nm (737,561 lbf.ft).



IQS 1-phase

IQS actuators are 1-phase versions of IQ actuators.

Direct torque range from 10 to 450 Nm (7.2 to 332 lbf.ft). With second stage gearboxes, multi-turn output torque up to 3,000 Nm (2,212 lbf.ft) and quarter-turn up to 203,000 Nm (149,725 lbf.ft).



IQD direct current

DC powered versions of IQ actuators. Voltage ranges available are 24, 48 and 110 VDC.

Direct torque output range 10.8 to 305 Nm (8 to 225 lbf.ft). With second stage gearboxes, output torque up to 1,500 Nm (1,106 lbf.ft) and quarter-turn up to 132,000 Nm (97,358 lbf.ft).



IQM / IQML modulating

Modulating IQ 3-phase electric actuator with solid state reversing starter in place of the electro-mechanical contactors. Fast-response remote control circuits for rapid control. The solid state starter includes an electronic motor 'brake' feature.

The IQM is suitable for up to 1,200 starts per hour (S4/ Class C). Direct seating torque output range from 10.8 to 544 Nm (8 to 400 lbf.ft). With second stage gearboxes, output seating torque up to 3,600 Nm (2,655 lbf.ft) and quarter-turn up to 58,000 Nm (42,778 lbf.ft).

IQML has a linear output drive providing modulating thrust output of up to 43 kN (9,667 lbf).



IQH high speed

IQH 3-phase electric actuators provide fast operation with positive seating without backdriving. High output speeds and generally irreversible operation provide a self-locking ability.

Speeds up to 259 rpm and torque range 75 to 397 Nm (55 to 293 lbf.ft).

Special designs

If you require an IQ or IQT actuator for duties that are not covered by our standard range, we are happy to discuss customised solutions.

Intelligent Integral Non-Intrusive Multi-turn & Linear Electric Actuators



IQT

IQT part-turn 1-phase, 3-phase and DC electric actuators are designed for isolating or regulating duties (S2 & S3 / Class A & B) of up to 1,200 starts per hour.

Direct torque output range from 50 to 3,000 Nm (37 to 2,214 lbf.ft).



IQTM modulating

IQTM 1-phase, 3-phase and DC electric modulating versions of the IQT actuator are designed for modulating duty up to 1,800 starts per hour (S4 / Class C). They feature fast-response remote control circuits for rapid control.

Torque range 50 to 3,000 Nm (37 to 2,214 lbf.ft).

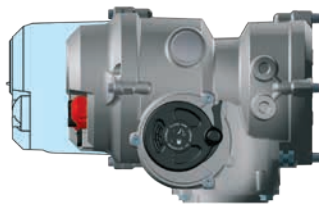

IQTN compact

IQTN part-turn 1-phase, 3-phase and DC electric actuators are designed for maritime and naval applications where space is limited. They feature a customised compact design that has been tested for shock tolerance. For more information please refer to PUB002-012.

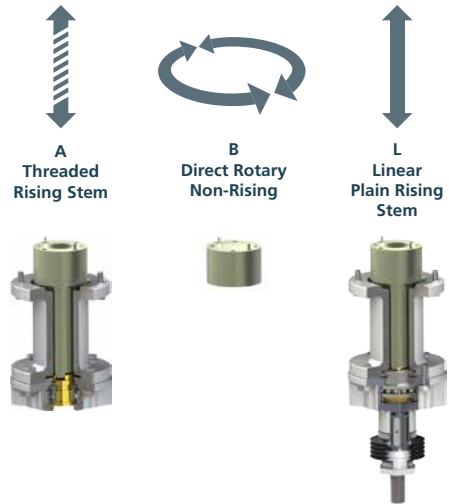

IQTF full-turn modulating

IQTF 1-phase, 3-phase and DC electric modulating actuators are capable of multi-turn, rising output, linear output and direct rotary output. This option is typically used for slow, high torque applications. Includes special fast switching control inputs for hardwired control. Modulating duty cycle up to 1,800 starts per hour (S4 / Class C). For full IQTF data please refer to PUB002-006.

- A = Torque range 20 to 250 Nm (14.8 to 184.5 lbf.ft)
- B = Torque range 20 to 3,000 Nm (14.8 to 2,214 lbf.ft)
- L = Thrust range 7.5 to 75.8 kN (1,693 to 17,036 lbf)

The drive outputs conform to actuator interface standards EN ISO 5210 for multi-turn and BS EN 15714-2 for linear.

The performances for the IQTF choke and control actuators are shown in Section 1.

IQT battery backup

For applications requiring operation in the event of loss of mains electrical supply, IQT, IQTM and IQTF* are available with internal battery** or connection to an externally supplied 24 VDC supply. Actuators can be configured to automatically move to a preset position or remain available for control on loss of AC mains.

* Limited turns available.

** Non-explosionproof only.

Advanced Modular Electric Actuators

CK range



CK modular design electric valve actuators

Rotork watertight CK range actuators are suitable for all valves in non-hazardous locations and includes standard multi-turn actuators through to intelligent Centronik equipped actuators and remote operation solutions.

- Multi-turn output torque up to 10,800 Nm (8,000 lbf.ft)
- Part-turn output torque up to 205,600 Nm (151,600 lbf.ft)
- Modular design provides an off-the-shelf solution for spares and upgrading
- Plug and socket connection for easier field wiring
- Continuous valve position indication even during power loss

- Non-intrusive setting via infra-red or optional *Bluetooth*[®] with the intelligent CKc - Centronik module
- Hollow output drive to accept rising valve stems
- Detachable thrust and non-thrust base options
- Secure manual handwheel drive fully independent of the motor drive train
- IP68 rating (8 m / 96 hrs) as standard provides enhanced environmental protection

See PUB111-001 for further details.

ExMax range



Explosionproof part-turn actuators

Compact, robust and lightweight electric part-turn actuator, designed for use in Ex areas for all gases, mists, vapours and dust.

- On/off modulating duty as standard
- 24-240 VAC/VDC universal power supply
- Standard ISO flanges available
- Torque range 5 to 150 Nm (3.7 to 110.6 lbf.ft)
- Explosionproof to international standards
- UL and CSA certified variants available

- Auto setup and selectable speeds
- Mechanical position indication
- Fail-safe option
- Ingress protection IP66/67
- Stainless steel housing (option)
- Temperature range: -40 to +50 °C (-40 to +122 °F)

See PUB113-003 for further details.

Precision Modulating Intelligent Linear & Part-turn Actuators

CVA range



Linear and part-turn precision modulating actuators

- Compact, viable alternative when good quality instrument air is not available in hazardous areas
- Low power, ultra-low energy consumption, suitable for solar powered applications
- 1-phase and DC power supply options
- Continuous, unrestricted modulation to S9, Class D (EN15714-2) duty
- Ability to fail-to-position on loss of power
- Unparalleled accuracy, repeatability, resolution and stiffness performance
- Perfect for demanding applications including, control valves, metering and dosing pumps and DC solar
- Comprehensive data logging
- Optional programmable fail-to-position option
- Analogue, digital and network control options
- Pakscan, HART, Profibus, Foundation Fieldbus and Modbus available
- Optional hard-wired RIRO (Remote In Remote Out) control
- Watertight IP68, NEMA 4 & 6, and explosionproof enclosures
- Option of Intrinsically safe I/O connections
- Non-intrusive setup / calibration using *Bluetooth* wireless technology
- Optional manual override
- CVL Linear: thrust range 890 to 22,241 N (200 to 5,000 lbf)
- CVQ Part-turn: torque range 54.2 to 271 Nm (480 to 2,400 lbf.in)

See PUB042-001 for further details.

CMA range



Multi-turn, part-turn and linear actuators

Compact, viable alternative when good quality instrument air is not available in hazardous areas. Modulation up to 2,000 starts per hour at 75% rated load, suitable for demanding applications including, control valves, metering and dosing pumps and DC solar.

- Option to fail-to-position on loss of power
- 1-phase and DC power supply options
- Excellent accuracy, repeatability, resolution and stiffness
- Analogue, digital and network control options
- IP66/67, NEMA 4 and explosionproof options
- Manual override, optional local controls and local display
- Linear: up to 5,004 N (1,125 lbf) seating thrust
- Part-turn: up to 124 Nm (1,100 lbf.in) seating torque
- Multi-turn: up to 45 Nm (400 lbf.in) rated torque with GB3

See PUB094-001 for further details.

ExMax+Lin/ ExRun range



Linear explosionproof actuators

ExMax + LIN and ExRun electric linear valve actuators are designed for use in Ex areas for all gases, mists, vapours and dust. ExMax + LIN with spring-return (safety function).

- Thrust range 500 to 10,000 N (112 to 2,248 lbf)
- Certificates: ATEX, IECEx, CSA, Inmetro, Kosha, EAC and others
- Optional spring-return configuration (3, 10 or 20 secs avail.)
- Control modes: On-off, 3 pos., modulating (0-10 VDC, 4 to 20 mA), depending on type
- 1-phase and DC power supply options
- Water and dust-tight IP66 rating
- Stainless steel housing (option for ExMax)
- Temperature range: -40 to +50 °C (-40 to +122 °F)
- Optional extras: Ex-d auxiliary switch with 2 adjustable contacts (2 mounting options available), Ex-e terminal box, manual override

See PUB113-001 for further details.

ExCos/ ExBin range



HVAC explosionproof sensors and switches

ExCos modulating sensors and ExBin binary switches are designed for direct use in hazardous locations. No additional modules in the panel required. No intrinsically safe wiring required. All parameters adjustable on site without additional tools or measuring devices. Sensors and switches for pressure, differential pressure, temperature and humidity available. Explosionproof design for all gases, mists, vapours and dust.

- Operating temperature range -20 to +50 °C (-4 to +122 °F)
- Measurement pressure range 0 to ±7,500 Pa
- Measurement temp. range -40 to +125 °C (-40 to +257 °F)
- Measurement humidity range 0 to 100% rH
- DC power supply
- Stainless steel housing (option)
- Certificates: ATEX, IECEx, CSA, Inmetro, Kosha, EAC and others
- Water and dust-tight IP66 rating, integrated junction box

See PUB113-001 for further details.



ExReg range



HVAC explosionproof control systems

ExReg controller system has been designed for use in Ex areas for all gases, mists, vapours and dust. In combination with Ex-Max actuators it is a closed loop control system for volume flow control (VAV, CAV), pressure, temperature and humidity.

- Operating temperature range -20 to +50 °C (-4 to +122 °F)
- Measurement differential pressure range 0 Pa to 300 Pa
- Measurement temp. range -40 to +125 °C (-40 to +257 °F)
- Measurement humidity range 0 to 100% rH
- 1-phase and DC power supply options
- Stainless steel housing (option)
- Certificates: ATEX, IECEx, CSA and others
- Water and dust-tight IP66 rating, integrated junction box
- Integral PID loop
- Pre-defined parameter sets for the most common control tasks
- Can be configured on site in the hazardous location

See PUB113-001 for further details.

High Performance Electric Actuators

Nuclear range

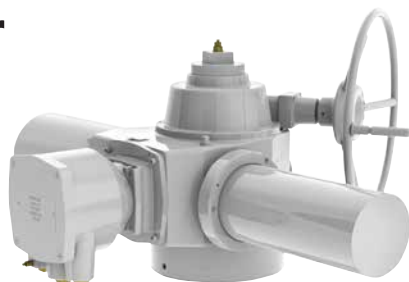

Nuclear safety related actuators

Rotork's NA, NE and ND ranges of electric actuators for the nuclear power industry are designed and tested to meet the latest plant specifications and industry standards such as **IEEE, RCCE** and **IEC**.

Rotork are an internationally audited and approved nuclear actuator manufacturer, all nuclear actuators are manufactured in accordance with strict nuclear industry quality assurance requirements.

- 3-phase AC or DC Power
- 60 year, 3,000 cycle design life
- Diagnostic ports for data acquisition
- Inside or outside containment
- Visual position indication
- Removable thrust base
- Plug and socket option
- Torque limiter option
- Thrust compensator option

See *PUB004-001* for further details.

K (high torque) range



High torque electric actuators

- Torque up to 7,000 Nm and thrust up to 1,115 kN
- Water ingress protection, not reliant on terminal cover or cable gland sealing – double-sealed to IP66/68 1.2 m for 48 hrs.
- Standard wiring diagrams for any valve type
- 3-phase power supply
- Thrust or non-thrust mounting flange dimensions to International (ISO) valve standards
- Advanced counter switch mechanism featuring combined torque position limit switches at each end of travel
- Integral starter and control circuit option (Rotork Syncropak)
- Three base options for each size of actuator

See *PUB009-001* for further details.

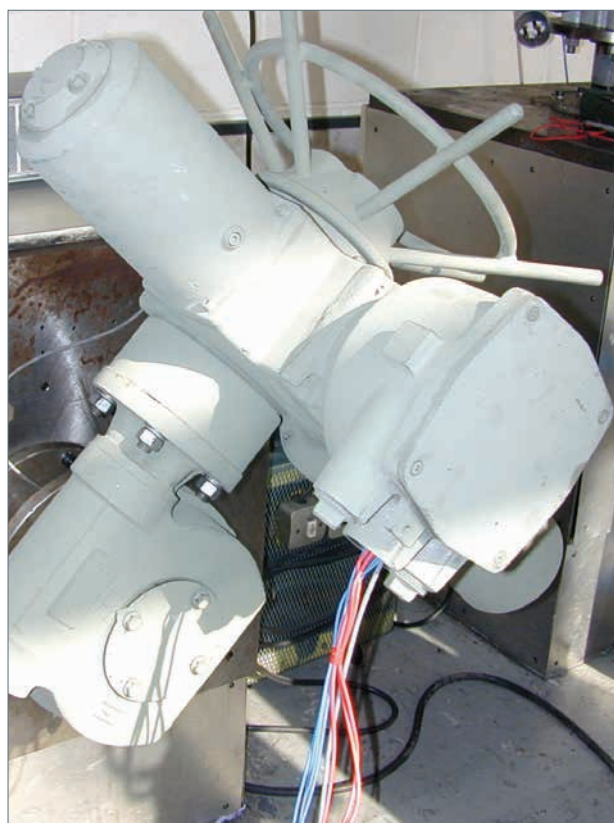

Combustion Air and Flue Gas Electric Actuators

SM-6000 range



Heavy-duty rotary actuators

- Up to 313° rotation
- Torque range up to 35,256 Nm (26,000 lbf.ft)
- Double o-ring sealing
- Continuous unrestricted modulating duty
- HART, Profibus and Foundation Fieldbus available
- Temperature range from -40 to 85 °C (-40 to 185 °F)
- Automatic torque limiting
- Self-locking drive system to hold in last position and prevent backdriving
- Manual override standard

See PUB052-001 for further details.

1700/ 5000 range



Heavy-duty rotary actuators

- Torques from 67 to 16,950 Nm (50 to 12,500 lbf.ft)
- Rotation 90° to 120°
- Modulating duty: 2,000 starts per hour
- Manual override standard
- Automatic torque limiting
- Self locking drive system to hold in last position and prevent back driving up to thrust rating
- AC input power (single- or 3-phase); DC input power version for 1700 only
- Temperature range from -40 to 85 °C (-40 to 185 °F)

See PUB050-001 for further details.

LA-2000 series



Heavy-duty linear actuators

- Stroke distance from 6" to 30" (152 to 762 mm)
- Thrust range up to 27,335 N (6,150 lbf)
- Modulating duty: 2,000 starts per hour
- HART available
- Temperature range from -40 to 65 °C (-40 to 150 °F)
- Automatic thrust limiting
- Self-locking drive system to hold in last position and prevent backdriving up to thrust rating
- ATEX approved for LA-2520
- Manual override standard

See PUB045-002 for further details.



High Performance Electric Actuators

ROM

range



ROM mechanical part-turn actuators

Small, compact, lightweight part-turn actuator with mechanical and LED local position indication and efficient yet simple gearing.

- On/off duty; manual override; self-locking; ISO flanges
- Available with local controls and phase rotation correction
- Torque range 8 to 650 Nm (6 to 480 lbf.ft)
- Wide range of supply voltages available
- 1-phase, 3-phase and DC power supply options
- Watertight IP68 rating
- High speed variant available
- **Options:** Bus communication, Analogue control and Feedback

See PUB008-001 for further details.

Q

range



Q 1-phase part-turn actuators

Small, electro-mechanical part-turn actuator environmentally sealed to IP68.

- Torque range 30 to 406 Nm (22 to 300 lbf.ft)
- Rugged compact, double-sealed
- Positive travel limitation through externally adjustable mechanical stops
- 1-phase power supply
- Marine option
- Simple remote control for basic applications
- **Options:** Bus communication, Analogue control and Feedback

See PUB007-001 for further details.

A

range



A Range multi-turn actuators

Explosionproof, electro-mechanical, multi-turn actuator.

- Available with remote starter 'SyncroSet' option
- Explosionproof
- Environmental sealing to IP68
- Torque range:
Direct drive 14 to 3,000 Nm (10 to 2,200 lbf.ft)
Part-turn up to 250,000 Nm (185,000 lbf.ft)
Multi-turn up to 40,800 Nm (30,000 lbf.ft)
- 1-phase, 3-phase and DC power supply options
- Isolating and regulating duty

See PUB003-001 for further details.

AWT

range



AWT multi-turn actuators

Watertight, electro-mechanical, multi-turn actuator.

- Torque range:
Direct drive 14 to 3,000 Nm (10 to 2,200 lbf.ft)
Part-turn up to 250,000 Nm (185,000 lbf.ft)
Multi-turn up to 40,800 Nm (30,000 lbf.ft)
- Oil bath lubricated IP68 double-sealed option
- Complete integral motor control or customer supplied motor control. Separate motor control available where required (SyncroSet actuator)
- 3-phase power supply
- Isolating and regulating duty

See PUB005-001 for further details.

Fluid Power Actuators and Control Systems

rotork® Fluid Systems

Rotork Fluid Systems has manufacturing facilities in Italy, Germany, Sweden, the UK and the USA, providing the capacity to produce a high volume of products, ensuring that you deliver your projects on time.

Rotork Fluid Systems delivers the following product ranges:

- Pneumatic rotary and linear valve actuators
- Hydraulic rotary and linear valve actuators
- Electro-hydraulic valve actuators
- Subsea valve actuators
- Vane-type pneumatic valve actuators
- Smart valve monitoring systems (SVM)
- Control systems

Centres of Excellence

Rotork Fluid Systems maintains a network of *Centres of Excellence* strategically located around the world. These centres hold stock, provide application engineering and packaging of control components as well as providing sales, service, installation and commissioning support.

Design and Testing

Rotork Fluid Systems has dedicated research and development facilities around the world combined with test facilities that include bespoke specialist testing systems, ensuring reliable operation and lifetime functionality of our products.

Our test systems incorporate the following features:

- Static continuous and dynamic analysis on a full range of torques throughout the complete stroke of the actuator
- Cyclic and repetitive tests, with variable parameters such as load, cycle times and temperature
- Automatic or manual setting and recording of pressure, position and temperature parameters
- Hydraulic filtration and flushing capabilities
- Torque testing up to 600,000 Nm (5,000,000 lbf.in)
- Thrust testing up to 10,000 kgf (22,046 lbf)
- Pneumatic pressures up to 120 bar (1,740 psi)
- Hydraulic pressures up to 360 bar (5,220 psi)

Most comprehensive range of pneumatic, hydraulic and electro-hydraulic actuators available.

Superior performance actuators for on/off duty, ESD, HIPPS, protective service and special valve applications.



Fluid Power Actuators

GT/RCR

ranges

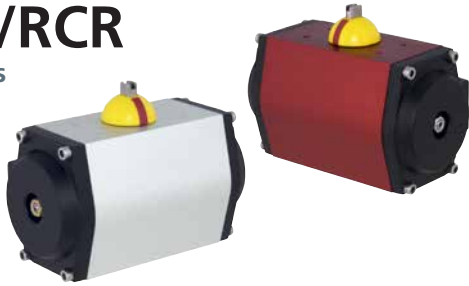

Rack and pinion actuators

- Double-acting and spring-return pneumatic actuators
- Extruded aluminium body with cast aluminium end caps
- Corrosion resistant cylinders and nickel-plated pinion
- Mechanical interfaces to ISO 5211, EN 15714-3-4, NAMUR VDI / VDE 3845
- Torque output to 2.4 to 15,300 Nm (135,400 lbf.in)
- Supply pressures 2 to 10 bar
- Actuators certified to ATEX 94/9/EC
- Certified suitable for use at SIL3 as a single device (IEC 61508)

See PUB014-004 for further details.

CP

range



Scotch yoke actuators

- Pneumatic actuators in double-acting and spring-return configurations
- Corrosion resistant cylinders
- Complies with EN60529 (1991) + (A1:2000) for IP67M
- Actuators certified to ATEX 94/9/EC
- Actuators certified in accordance with PED 97/23/EC
- Torque output to 4,500 Nm (39,800 lbf.in)
- Certified suitable for use at SIL3 as a single device in accordance with IEC 61508

See PUB013-001 for further details.

RC200 RCI200

ranges



Compact scotch yoke actuators

- Extremely compact scotch yoke pneumatic actuator
- Double-acting and spring-return configurations
- Contained spring module for safety and convenience
- Torque output to 4,400 Nm (38,000 lbf.in)
- Valve mounting dimensions per ISO 5211/DIN 3337
- Certified suitable for use at SIL3 as a single device (IEC 61508)
- Actuators certified in accordance with PED 97/23/EC
- Actuators certified to ATEX 94/9/EC

See PUB014-001 (RC200) and PUB014-002 (RCI200) for further details.

GP/ GH

ranges



Heavy-duty scotch yoke actuators

- Pneumatic and hydraulic actuators in double-acting and spring-return configurations
- Corrosion resistant cylinders
- Complies with EN60529 (1991) + (A1:2000) for IP67M
- Actuators certified to ATEX 94/9/EC
- Actuators certified in accordance with PED 97/23/EC
- Torque output to 600,000 Nm (5,000,000 lbf.in)
- Certified suitable for use at SIL3 as a single device (IEC 61508)

See PUB011-001 (GP/GH) for further details.

Fluid Power Actuators

CQ range



Compact quarter-turn self-contained actuators

The CQ self-contained actuator is a fully concentric design based on a helical mechanism, transforming the linear motion of the piston into a quarter-turn rotation of the valve stem.

- Weatherproof housing suitable for harsh environments
- Applications: SIL3, functional integrity, safety, limited space
- Pneumatic and hydraulic, single- and double-acting
- Torques up to 150,000 Nm (higher upon request)
- Stroke adjustment $90^\circ \pm 5^\circ$
- Std. temp. range -30 to 100 °C (-22 to 212 °F)
Low temp. range available down to -60 °C
- Certified to IP66M/IP68, PED, ATEX, IECEx, EAC

See PUB119-001 for further details.

LP/ LH ranges



Linear actuators

- Pneumatic and hydraulic actuators in double-acting and spring-return configurations
- Electroless nickel-plated cylinders, chromium-plated piston rods
- Hammer blow and standard valve stem coupling designs available
- Thrust up to 5,000,000 N (1,124,000 lbf)

See PUB020-001 for further details.

RH range



Heavy-duty rack and pinion actuators

- Double-acting and spring-return configurations
- Heavy-duty hydraulic actuators with cast iron bodies and torque output to 3,400 Nm (30,000 lbf.in)
- Electroless nickel-plated cylinders for corrosion resistance
- Valve mounting dimensions per ISO 5211 DIN 3337
- Complies with EN60529 (1991) + (A1:2000) for IP67M
- Actuators certified to in accordance with PED 97/23/EC
- Certified suitable for use in SIL3 as a single device in accordance with IEC 61508

See PUB019-004 for further details.

RHQ range

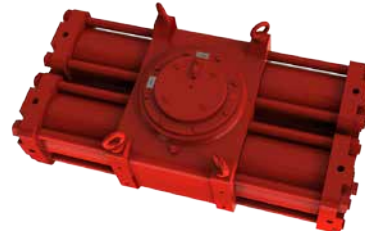

Extreme-duty rack and pinion actuators

- Hydraulic, double-acting actuators
- Balanced, compact design
- Totally enclosed weatherproof housing to IP68
- Electroless nickel-plated cylinders with redundant piston seals
- Precision machined rack and pinion mechanism with zero backlash
- Female input shaft allows direct mounting to valve topworks
- Torque output to 5,650,000 Nm (50,000,000 lbf.in)
- Supply pressures to 207 bar (3,000 psi)

See PUB019-009 for further details.

Fluid Power Actuators

GO range



Gas over oil actuators

- Low- or high-pressure control logic options
- Hydraulic manual override standard
- Speed control in both directions standard
- PED or ASME approved gas / oil and power gas storage tanks
- Complies with EN60529 (1991) + (A1:2000) for IP67M
- Actuators certified to ATEX 94/9/EC
- Actuators certified in accordance with PED 97/23/EC
- Torque output to 600,000 Nm (5,000,000 lbf.in)

See PUB017-001 for further details.

HPG range



Direct high-pressure gas actuators

- Hydraulic manual override standard
- Speed control in both directions standard
- Complies with EN60529 (1991) + (A1:2000) for IP67M
- Actuators certified to ATEX 94/9/EC
- Actuators certified in accordance with PED 97/23/EC
- Torque output to 600,000 Nm (5,000,000 lbf.in)

See PUB016-001 for further details.

ELB



Pipeline pressure monitoring system

Rotork's ELB, the electronic linebreak detection system is designed to continuously monitor pipeline pressure and provide automatic valve actuator movement to an emergency position.

- Comprehensive data logging with real-time clock
- Configuration and data retrieval via Rotork *Bluetooth*® Setting Tool or PC (using Rotork's Insight2 software)
- Configurable fail position to close, open, stay put
- Optional manual reset requirement
- Local controls for open, close, local / remote / stop
- Remote control via either hard-wired connections or Modbus® serial communication protocol

See PUB127-001 for further details.



K-TORK

range



Vane actuators

- Pneumatic actuators in double-acting and spring-return configurations
- Compact no-sideload, constant-torque design with output to 18,300 Nm (155,000 lbf.in)
- Certified to IP66M / IP67M and meets NEMA 4 / 4X
- CE marked and certified in accordance with ATEX 94/9/EC
- Complies with ANSI / AWWA C540-02 and C541-08
- Conforms to VDI / VDE 3485 control accessory mounting standards
- Modulating accuracy of 0.25% or better
- Capable of millions of operations at fast cycle times

See PUB097-001 for further details.

TYPE K

range



Damper drives

- Direct 'drop-in place' design matches existing damper drive take-out dimensions
- Rotary and linear versions available
- Torque output up to 28,201 Nm (250,000 lbf.in)
- High-speed operation as quick as 3-5 seconds full scale
- High temperature options up to 149 °C (300 °F)
- Highly accurate and responsive
- Designed for safety and serviceability in harsh environments
- Infinite duty cycle
- **Control options:** Profibus, HART and Foundation Fieldbus bus control. Pneumatic, analogue and digital positioners

See PUB000-062 for further details.

Self-contained Hydraulics

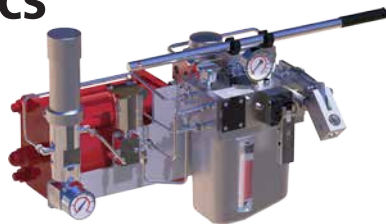

Self-contained fail-safe actuators

- Manually energised, spring-return fail-safe operation
- Cost-effective solution for infrequently operated valves and dampers
- Watertight or explosionproof construction
- Highly configurable with a multitude of options

See PUB134-001 for further details.

Twin Power

range



Mechanical fluid power stepping actuators

- Pneumatic or hydraulic versions available
- Torque output to 800 Nm (7,080 lbf.in)
- Modular system for flexibility
- Robust design can be supplied suitably trimmed for various severe or hazardous environments

See PUB025-002 for further details.

Fluid Power Actuators

Skilmatic SI 3rd Generation range

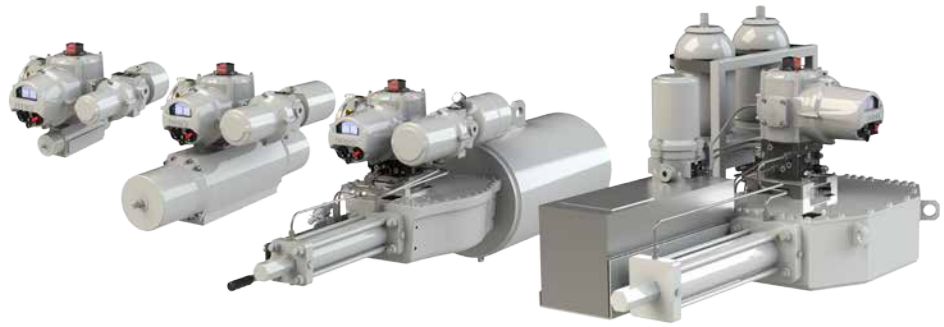

Electro-hydraulic actuators

The Skilmatic SI₃ range of intelligent self-contained electro-hydraulic actuators designed to meet today's control and safety needs for both two position and positioning control applications. Featuring a large display for position, pressure, diagnostics and status indication and utilising *Bluetooth*[®] for configuration, setting and downloading actuator data.

- Electrical powered, 1-phase, 3-phase or 24 VDC
- Fail-safe to close, open or lock in last position
- Spring-return or double-acting
- Linear thrusts: 1.7 to 5,500 kN (382 to 1,236,000 lbf)
¼ turn torques: 65 to 500,000 Nm (575 to 4,425,000 lbf.in)
- Adjustable operating speeds with stepping facility and optional internal flow control valves
- Configurable Partial Stroke Testing (PST)

- Single or dual ESD/PSD input with solenoid configuration options
- Positioning control option 4-20 mA input & output, resolution 0.3%
- Network options *Pakscan*[™], Profibus[®], Modbus[®], HART[®] and Foundation Fieldbus[®]
- Datalogger, recording up to 3,000 events
- Configurable status & alarm outputs
- Watertight & explosionproof Exdb IIB & IIC T4 –ATEC, IEC, cCSAus and EAC
- TÜV Functional Safety SIL certified to IEC 61508:2010
- Operating temperature -50 to +70°C (-58 to +158°F)

See PUB021-001 for further details.

ACS range

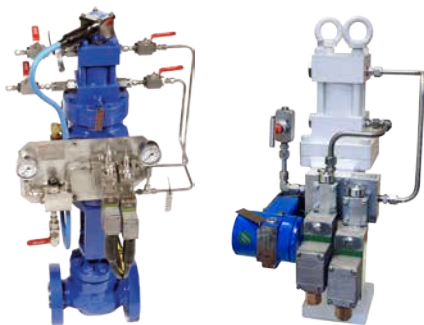

Control and choke valve actuators

The ACS range of modulating actuators are a cost effective solution for the positioning of control and choke valves.

- Extended opening and closing operating speeds with all optional features associated with the double-acting, single-acting and quarter-turn options
- Remote switching to activate / deactivate stepping function
- Reliable operation reduces cost of ownership
- Compact design reduces installation cost
- Lower cost of maintenance

See PUB025-003 for further details.

Skilmatic SB range



Compact Electro-hydraulic actuators

- Self-contained electrically operated with internal low-pressure electro-hydraulic control module
- Spring-return for fail safe open or close
- Dual redundant hydraulic oscillating pumps
- Single or dual fail safe solenoids
- 1-phase 115 or 230 VAC power supply
- Two-position control with torque / pump protection
- Watertight and explosionproof
- Double-sealed control module with separate terminal and cable gland compartments
- Adjustable electro-mechanical volt-free limit switches

See PUB021-020 for further details.

Hiller range

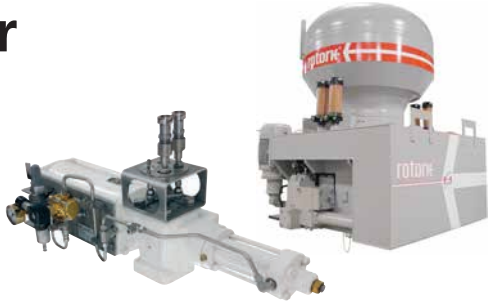

Fluid power nuclear applications

The Hiller range encompasses rotary and linear pneumatic and hydraulic actuators in double-acting and spring-return configurations. The range also includes specialised linear hydro-pneumatic actuators designed to deliver very precise speed control.

Quality assurance for these products conforms to 10 CFR 50 APP B, 10 CFR 21, ANSI N45.2 and has been audited by both NUPIC and NIAC. Environmental and seismic qualifications comprise IEEE 323, 344 and 382.

Hiller products are supported with a stock of more than 10,000 spare parts for safety related service.

See publication PUB068-001 for further details.

HPU range

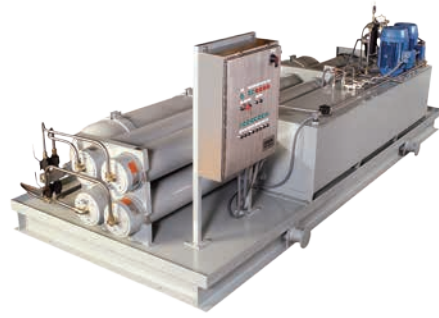

Hydraulic power units

- Hydraulic fluid capacity from 19 to 7,570 litres (5 to 2,000 U.S. gal)
- Operating pressures up to 345 bar (5,000 psi)
- Flow rates up to 3,785 lpm (1,000 U.S. gpm)
- Electrical classifications: NEMA 4, 4x, 7 or comparable CSA or ATEX ratings
- Custom engineered solutions to meet the specific demands of each application
- Sole source responsibility for the complete operating system including field survey, design, fabrication, test, installation and start-up
- Best-in-class documentation and service manuals

See PUB062-001 for further details.

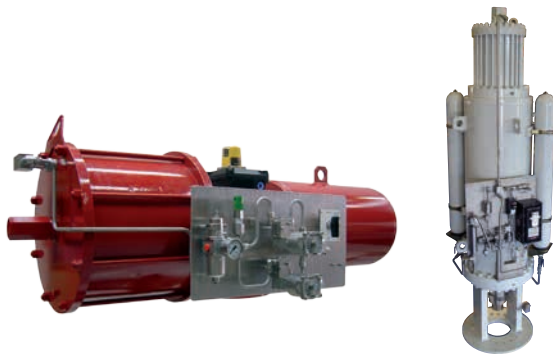

Control systems

Control component packages are a part of any actuator / valve installation. Rotork has extensive experience in the design and assembly of all types of fluid power control systems to satisfy any customer requirement for on / off, modulating or ESD (emergency shutdown) service. Packages can be mounted on a panel or in a cabinet and mounted either on the actuator or at a remote location.

Rotork offers components from all leading industry suppliers as well as those of our own design including limit switch housings, quick exhaust valves, pneumatic and hydraulic manifolds, filter regulators, shuttle valves, linebreak safety systems, partial stroke testing and a torque limiting device.



Subsea range



Subsea actuators

The subsea product range encompasses actuator and gearbox designs for retrievable and non-retrievable applications. We are familiar with supplying subsea product to meet the harsh conditions and stringent demands of subsea applications.

- Hydraulic quarter-turn and linear subsea actuators in double-acting and spring-return configurations
- Subsea and splashzone trims
- Retrievable and non-retrievable designs
- Multitude of design options available
- Installed base dating back to 1992 at depths up to 2,500 m
- Smart Valve Monitor (SVM) partial stroke testing compatible

See PUB022-001 for further details.

SVM range



Smart Valve Monitor (SVM)

- Compatible with fluid power actuators and valves for on / off service
- Safe and hazardous area versions available
- Comprehensive and versatile partial stroke testing – tests all final elements
- Data logging of valve performance for diagnostics and preventative maintenance
- Suitable for use at any SIL rating
- Can interface with DCS / ESD common system
- Improves SIL verification performance of final elements

See PUB026-001 and PUB026-002 for further details.

Masso range

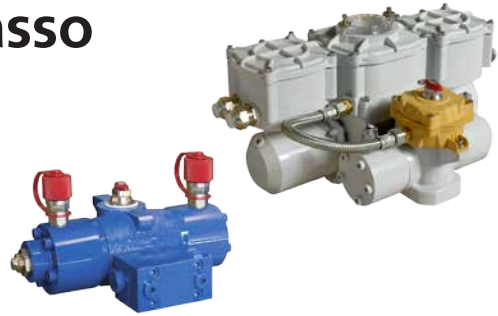

Valve Remote Control System (VRCS)

With more than 80 years of experience in specialist design, fabrication and installation of actuators and VRCS, the Masso range provides safety critical hydraulic and electro-hydraulic solutions for the marine and offshore industry.

CRCS – The Masso range hydraulic VRCS combines traditional hydraulic systems with advanced communication technologies.

ADCS – The Masso range electro-hydraulic system provides a flexible control solution, while bringing several advantages to shipyards and ship-owners worldwide.

Both systems are compatible with most Integrated Automation Systems (IAS).

See PUB121-001 for further details.



Valve Gear Operators and Accessories

rotork® Gears

Rotork Gears is a specialist supplier of gearboxes, adaptations and accessories to the international valve and actuator industry with manufacturing plants in the UK, the Netherlands, Italy, China, the USA and India.

Rotork Gears delivers the following product ranges:

- Manual and motorised multi-turn gearboxes
- Manual and motorised quarter-turn gearboxes
- Worm gear quarter-turn gear operators
- Subsea quarter-turn gear operators
- Override quarter-turn gear operators
- Mounting kits and accessories

Engineering and Working Capabilities

Rotork Gears delivers innovative solutions to suit individual needs, backed by Rotork quality and after-sales care.

Our products are world-class in design and meet or exceed national and international standards. Our specialist application engineering, continuous testing of materials and the life testing of completed gearboxes ensures quality.

Testing Facilities

Rotork Gears has extensive multi-turn and quarter-turn gearbox test facilities at its manufacturing locations including torque testing, life testing, overload testing and environmental testing in-house.

Reliability and Quality Assurance

Rotork is committed to fully understanding customer needs and expectations, and meeting or exceeding these needs. Rotork Gears has an established quality management system that meets the requirements of BS EN ISO 9001.

Rotork Gears is committed to:

- Building business success through customer satisfaction
- The promotion and full understanding of customer needs within the organisation
- Continuous improvement of products and customer service operations
- Creating a quality culture by making continuous improvement and quality a fundamental part of every employee's performance and responsibility

Gearboxes and operators designed to withstand harsh environments including subsea and nuclear installations.

Mounting brackets, extension shafts, pedestals and accessories for the valve and actuator industry.



Quarter-turn Products

232 range



Light-duty worm gear operators

Light-duty cast aluminium quarter-turn gearboxes suited for HVAC, fire protection, and general industrial applications.

Torque range up to 1,500 Nm (1,106 lbf.ft).
7 sizes. Ratios from 37:1 to 45:1.

- Lightweight
- Rugged construction
- Removable output drive sleeves
- IP65
- High pressure aluminium cast housing
- Protected input shaft

242 range



Quarter-turn worm gear operators

Robust and light weight quarter-turn cast iron gearbox for low torque manual applications. Suited for ball, plug and butterfly valves.

Torque range up to 2,100 Nm (1,549 lbf.ft).
6 sizes. Ratios 40:1 to 60:1.

- Worm gear
- Manual drive
- Designed using the latest analytical design tools

AB range



Quarter-turn worm gear operators

Heavy-duty cast iron quarter-turn gearboxes suited for ball, plug and butterfly valves serving the water, gas, chemical, power, and demanding industrial applications.

Torque range up to 32,000 Nm (23,600 lbf.ft).
15 sizes. Ratios from 34:1 to 729:1.

- Cast iron
- Axial needle bearings
- Rugged construction for all environments
- IP67
- **Options:** Stainless steel input shaft. Ductile iron. IP68. AWWA. Various environments. Padlockable handwheels. Limit switches. High and low temperatures. Buried service.

242P range



Nuclear rated manual worm gear operators

The 242P is a range of nuclear safety related gearboxes, qualified for outside containment and passive duty. The 242P gearboxes are intended for the operation of ball, butterfly, plug and any other quarter-turn valves.

Torque range up to 1,000 Nm (8,851 lbf.in).
5 sizes. Ratios of 40:1 to 60:1.

Quarter-turn Products

ABM range



Motorised quarter-turn gearboxes

Quarter turn devices for the motorised operation of plug, ball and butterfly valves and power & process dampers.

Torque range up to 2,000 Nm (1,475 lbf.ft).
4 sizes. Ratios 34:1 to 198:1.

- Supports electric actuator weight up to 46 kg (101 lbs) and a speed up to 96 rpm
- Input: F/FA10
- Ductile iron housing and protected steel input shaft
- Axial thrust bearings
- Removable insert
- IP67 and ATEX approved
- **Options:** High and low temperatures, Firesafe to ISO 10497, IP68 marinised and buried service.

IW range

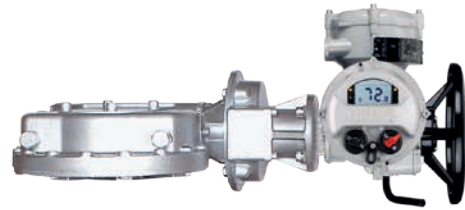

Motorised quarter-turn gearboxes

Complete range of heavy-duty cast and ductile iron quarter-turn worm gearboxes suited for plug, ball and butterfly valves serving the water and waste water, gas, chemical, power, and general industrial applications.

Torque range up to 850,000 Nm (626,890 lbf.ft).
21 sizes. Ratios from 40:1 to 9,600:1.

- Comprehensive gear ratios with a selection of input reducers
- High efficiency
- Angular contact bearings
- Removable output drive sleeves
- IP67
- **Options:** Ductile iron. IP68. AWWA. Nuclear. All types of environment. High and low temperatures. Lever arms. Travelling nut for applications requiring more or less 90 degrees travel. Buried service.

IW range

Heavy-duty cast and ductile iron quarter-turn worm gearboxes suited for plug, ball and butterfly valves serving the water, gas, chemical, power, and general industrial applications.

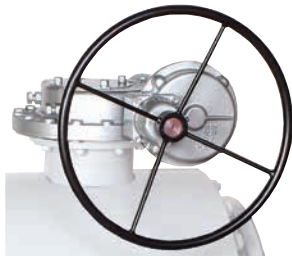

Manual quarter-turn operators

Torque range up to 850,000 Nm (626,890 lbf.ft).
21 sizes. Ratios from 40:1 to 9,600:1.

- Comprehensive gear ratios with a combined selection of input reducers
- High efficiency
- Removable output drive sleeves
- IP67
- Angular contact bearings
- **Options:** Ductile iron. IP68. AWWA. Nuclear. All types of environment. High and low temperatures. Padlockable handwheels. Limit switches. Lever arms. Travelling nut for applications requiring more or less than 90 degrees travel. Buried service.

MOW range



Worm gearboxes

Heavy-duty quarter-turn modulating gearboxes suited for control valves.

Torque range up to 47,000 Nm (34,500 lbf.ft).
9 sizes. Ratios from 40:1 to 3,000:1.

- Up to 1,200 starts per hour
- Ground and polished worm shaft
- Aluminium bronze worm wheel
- Comprehensive gear ratios combined with a selection of spur input reducers
- Angular contact bearings
- Removable output drive sleeves
- **Options:** All types of environment.

Quarter-turn Products

IWN range



Nuclear rated worm gearboxes

Heavy-duty quarter-turn gearboxes suited for plug, ball and butterfly valves in nuclear installations. Built to exceed the IEEE 382 specification and the 10CFR50 quality standard. Fully tested for inside containment and active duty but can also be used for outside containment, passive duty.

Torque range up to 48,809 Nm (36,000 lbf.ft).
7 sizes. Ratios from 40:1 to 70:1

- Ductile iron cast body
- Viton o-rings
- Special bearings
- Nuclear grease

300 range



Stainless steel gear operators

Light-duty pressed stainless steel quarter-turn gearboxes suited for pharmaceutical, wash down, and corrosive environments.

Torque range up to 1,000 Nm (738 lbf.ft).
3 sizes. Ratios from 37:1 to 45:1.

- 304 stainless steel housing and input shaft
- Aluminium bronze worm wheel
- Lightweight
- Suitable for corrosive environments
- IP65
- Removable output drive sleeves

AB-SS range



Stainless steel gear operators

Heavy-duty stainless steel 316 housing quarter-turn gearboxes suited for plug, ball and butterfly valves serving the water, gas, chemical and power industries in corrosive environments.

Torque range up to 26,000 Nm (19,177 lbf.ft).
14 sizes. Ratios from 37:1 to 592:1.

- Worm gear
- Manual drive
- Stainless steel 316 housing
- Stainless steel 316 input shaft
- Stainless steel 316 fasteners

WG-SS range



Stainless steel gearboxes

Heavy-duty stainless steel 316 housing quarter-turn gearboxes suited for plug, ball and butterfly valves serving the water, gas, chemical and power industries in corrosive environments.

Torque range up to 125,000 Nm (92,195 lbf.ft).
2 sizes. Ratios up to 3,795:1.

- Worm gear
- Manual or electric actuator drive
- Stainless steel 316 housing
- Stainless steel 316 input shaft
- Stainless steel 316 fasteners

Quarter-turn Products

ILG-D range



Override quarter-turn gear operators

Complete range of manual declutchable sandwich override quarter-turn gearboxes for double-acting pneumatic actuators.

Torque range up to 17,000 Nm (13,000 lbf.ft).
9 sizes. Ratios from 35:1 to 468:1.

- Protected input shaft
- Cast iron housing
- Axial needle bearings
- IP65
- **Options:** High and low temperature. ISO drive coupling. Solenoid valve to evacuate air automatically. IP67.

ILG-S range



Override quarter-turn gear operators

Complete range of sandwich manual override quarter-turn gearboxes for spring-return pneumatic actuators.

Torque range up to 32,000 Nm (23,600 lbf.ft).
10 sizes. Ratios from 34:1 to 729:1.

- Protected input shaft
- Cast iron housing
- Axial needle bearings
- IP65
- **Options:** High and low temperature. ISO drive coupling.

Lever Arm range



Lever arms for damper operation

Used on dampers to transfer the 90° operation from the worm gearbox to the damper spindle.

- **Option for IW range:** This is an optional feature on all our IW and MTW ranges of worm gearboxes.

WGS range



Subsea quarter-turn gearboxes

The WGS range of quarter-turn gearboxes are designed for heavy-duty subsea applications at any depth with carefully chosen materials to offer the highest level of reliability required in this very harsh environment. The operator is equipped with membrane or piston type pressure compensators to balance the pressure and allow them to work at any depth.

Torque range from 2,200 to 500,000 Nm (1,623 to 368,800 lbf.ft).

- Worm shaft supported on taper roller bearings
- High strength alloy steel worm screw hardened and ground
- Vertical or horizontal carbon steel ROV input (class 2 to 7)
- Stroke: 0 to 90° (± 5° adjustable)

Quarter-turn Products

ABLX (FM-UL) range



Quarter-turn worm gear operators

Cast iron quarter-turn gearboxes with integrated limit switches for remote position indication suited for fire protection.

Torque range up to 1,620 Nm (1,196 lbf.ft).
4 sizes. Ratios from 34:1 to 40:1.

- Cast iron housing
- Rugged construction
- Removable output drive sleeves
- IP67
- Different types of position indicators
- Suitable for FM/UL/APSAD applications

232LX range



Quarter-turn worm gear operators

Light-duty cast aluminium quarter-turn gearboxes with integrated limit switches for remote position indication suited for fire protection.

Torque range up to 500 Nm (366 lbf.ft).
2 sizes. Ratios 37:1 to 45:1.

- High pressure aluminium cast housing with stainless steel input shaft
- Light weight
- Suitable in corrosive environments
- IP65
- Removable output drive sleeves
- Powder coated
- Different types of position indicators

FB range

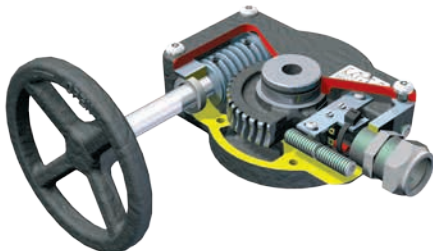

Worm gear operators

Quarter-turn cast iron gearbox suitable for use with fire protection (i.e. sprinkler) systems, includes limit switches to be incorporated into a supervisory electrical circuit. Designed and tested specifically to meet UL1091 specification and FM1112 Approval.

Torque range up to 1,000 Nm (737 lbf.ft).
5 sizes. Ratios from 40:1 to 60:1.

- Worm gear
- Manual drive
- 3 x overload capacity
- 1,000 cycles

BR range



Bronze worm gear operators

The BR series gear operators are manufactured from high quality cast aluminium bronze and stainless steel materials and designed for extended life operation of valves in corrosive man hole and vault steam distribution environments where road salts, standing water and elevated temperatures are common.

Torque range to 7,000 Nm (5,163 lbf.ft).
3 sizes. Ratios from 34:1 to 217:1.

- Temperature range up to +200 °C (+392 °F)

Multi-turn Products

MTW range



Worm gearboxes

The multi-turn worm gearboxes are used for applications such as sluice gates and dampers.

Torque range up to 162,000 Nm (119,000 lbf.ft).
11 sizes. Ratios from 40:1 to 5,760:1.

- Ground and polished worm shaft
- Aluminium bronze worm wheel
- Comprehensive gear ratios combined with a selection of spur input reducers
- Angular contact bearings supporting worm shaft
- Removable output drive sleeves
- **Options:** Travelling nut for applications requiring mechanical stops. Lever arms. AWWA. All types of environment.

IB range



Motorised multi-turn gearboxes

Complete range of heavy-duty cast iron multi-turn bevel gearboxes suited for the most demanding motorised applications for cast and fabricated sluice gates, gate valves and globe and pinch valves.

Torque range up to 8,135 Nm (6,000 lbf.ft).
Thrust range up to 1,320 kN (296,750 lbf).
13 sizes. Ratios from 1:1 to 120:1.

- **Common options for IB:** Spring loaded temperature compensators. Various position indicators. AWWA. High and low temperature. Nuclear. All types of environment. IP68. Cast steel.

IBN range



Nuclear rated bevel gearboxes

Heavy-duty multi-turn bevel gearboxes suited for nuclear installations. Built to exceed the IEEE 382 specification and the 10CFR50 quality standard. Fully tested for inside containment and active duty but can also be used for outside containment, passive duty.

Torque range up to 8,135 Nm (6,000 lbf.ft).
Thrust range up to 1,320 kN (296,750 lbf).
6 sizes. Ratios from 2:1 to 8:1.

- Ductile iron cast body
- Viton o-rings
- Special bearings
- Nuclear grease

HOB/MPR ranges



Bevel gear operators

Cost effectively designed commodity hand operated bevel gears suited for sluice gates, gate, and globe valves.

Torque range up to 8,018 Nm (5,914 lbf.ft).
Thrust range up to 1,557 kN (350,028 lbf).
11 sizes. Ratios from 2:1 to 81:1.

- Cast iron body
- Maintenance free
- IP67
- **Options:** All types of environment. Position indicators. IP68.

Multi-turn Products

HOS/MPR ranges

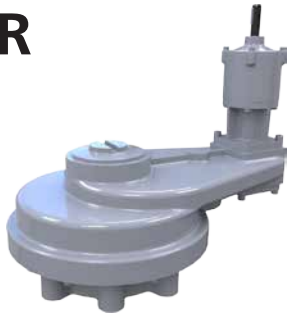

Spur gear operators

Multi-turn devices intended for the manual operation of gate, globe, sluice and penstock valves. For use above and underground with upward or downward input orientation.

Torque range up to 15,917 Nm (11,740 lbf.ft).
Thrust range up to 1,557 kN (350,000 lbf).
14 sizes. Ratios from 2.04:1 to 151.9:1.

- Totally enclosed gearing
- Cast iron gearcase
- IP67

IS range



Motorised multi-turn gearboxes

Complete range of heavy-duty cast iron multi-turn spur gearboxes suited for the most demanding motorised applications where the gearbox input shaft needs to be parallel with the valve stem for globe and gate valves and sluice gates.

Torque range up to 43,386 Nm (32,000 lbf.ft).
Thrust range up to 2,900 kN (652,000 lbf).
20 sizes. Ratios from 1:1 to 360:1.

- **Common options for IS:** Spring loaded temperature compensators. Various position indicators. AWWA. High and low temperature. Nuclear. All types of environment. IP68. Cast steel.

ISN range



Nuclear rated spur gearboxes

Heavy-duty multi-turn spur gearboxes suited for nuclear installations. Built to exceed the IEEE 382 specification and the 10CFR50 quality standard. Fully tested for inside containment and active duty but can also be used for outside containment, passive duty.

Torque range up to 43,386 Nm (32,000 lbf.ft).
Thrust range up to 2,224 kN (500,000 lbf).
3 sizes. Ratios from 6:1 to 24:1.

DSIR range

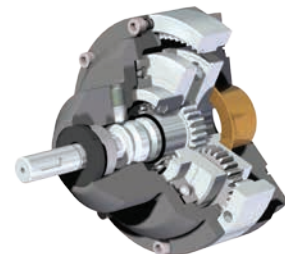

Dual speed gear operators

The Dual Speed Input Reducer is used to reduce the number of input turns required and therefore the operating time on manual gearbox applications. It can be used with any manual gearbox which can be fitted with an F14 or FA14 input flange.

Output torque 720 Nm (6,373 lbf.in).
Ratio can be switched between 1:1 and 4.25:1.

Multi-turn Products

NTB range



Bevel gear operators

Cost effectively designed bevel gearboxes suited for valves which do not transfer thrust to the operator.

Torque range up to 700 Nm (516 lbf.ft).
2 sizes. Ratios 2:1 and 4:1.

- Cast iron body
- Maintenance free
- IP67
- **Options:** All types of environment. Various Position indicators. IP68. Approval to GOST standard ST CKBA 062-2009 "Valve Rotation & Actuator Mounting Dimensions".

NTBG range



Non-thrust bevel GOST Standard

Designed specifically to meet the requirements of valves complying with the Russian GOST standard ST CKBA 062-2009.

The NTBG series gearboxes are intended for the operation of gate and globe valves without a thrust capacity requirement.

Torque range up to 10,000 Nm (7,376 lbf.ft).
Various sizes. Ratios from 2:1 to 120.2:1.

RAB range



Bevel gear operators

The Radial Acceptance Bevel is suitable for AWWA and where side load movement is likely to happen on penstocks or gate valves.

Torque range up to 678 Nm (500 lbf.ft).
Thrust range up to 178 kN (40,000 lbf).
2 sizes. Ratios from 2:1 to 6:1.

- Comprehensive gear ratios combined with a selection of input reducers
- Removable drive sleeves designed to accommodate for heat build-up
- Tapered roller bearing to withstand side loading
- IP68
- **Options:** Various types of position indicators. All types of environment.

DSB range

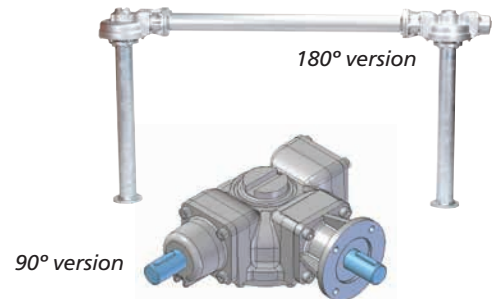

Dual shaft bevel gear operators

Complete range of multi-turn bevel gearboxes with two shafts for use with dual stem sluice gates and penstocks.

Torque range up to 8,135 Nm (6,000 lbf.ft).
Thrust range up to 1,320 kN (296,750 lbf).
13 sizes. Ratios from 1:1 to 120:1.

- Ductile iron baseplates
- Comprehensive gear ratios combined with a selection of spur input reducers
- Pinions mounted on ball bearings
- IP67
- **Options:** All types of environment. Various position indications. IP68. Input shafts available at 90° & 180° to each other.

Mounting kits

ball, butterfly and plug valve kits



Ball, butterfly and plug valve kits designed to order, precision CNC machined in stainless steel

Rotork has manufactured, designed and supplied standard and non-standard mounting brackets to the valve and actuator industry since 1987. ISO 9001 accreditation was achieved in 1992. Rotork supply the following components to the highest standards, with market leading delivery times:

- Mounting brackets and couplings
- Extensions
- Pedestals
- Locking devices
- Flexible drive technology
- Chainwheels, handwheels and spring-return handles

See PUB063-040 for further details.



Locking levers - secure and tamper proof

- Locking plates, for quarter-turn ball and butterfly valves
- Multi-turn locking flanges for valves and gearboxes
- Interlocked valves

See PUB063-040 for further details.



Spool and pedestal adaptors

Quarter-turn valve adaption for rack and pinion or pneumatic actuators can be provided in the form of spool or pedestal type mounting kits.

These are fully enclosed adaptors with options of DD, square or keyed drives.

Construction materials will be carbon steel, supplied complete with fasteners, painted or natural.

- Valves from 1/4" to 48"
- F03 - F35 Flanges - ISO 5211/ DIN 3337
- Welded to ASME 9 standards
- Square, key or double D drive
- 100 to 500 mm in length
- **Options:** o-ring seals, stress calculations, material certification.

See PUB063-030 for further details.



Rotohammer Chainwheels

range



Chainwheels and valve extensions

Rotohammer offers the very best solutions for hard-to-reach and difficult to operate valves, with the purpose of protecting people and equipment with safe, dependable valve operation.

Rotohammer manufacture clamp-on-sprockets chainwheels to fit handwheels size from 4" to 40". They are made with different materials (ductile, aluminium and stainless steel) and protections to cater for very harsh environments.

Rotohammer also make a variety of innovative custom solutions.

Remote mounting and extension spindles

Valve and actuator remote mounting and extension spindles.

Remote actuator mounting can be achieved using valve extension spindles or pedestal adaptors. Design and manufacture is done in house for specific applications. Lengths can be from 500 mm to 8 m, in stainless steel or carbon steel.

Extension spindle

- Underground applications
- Customer specified extension
- Welded construction for weight saving
- Position indication option
- Suitable for manual or actuated drives
- **Options:** Oil filled, environmental sealing, galvanised, plain or dynamic bearings, swivel joints.

Remote position indicator

Mechanical remote position indicators for buried service and shaft extension applications. 3 sizes. Ratios: ECL1 up to 35:1, ECL2 up to 120:1, ECL3 up to 394:1.

W100 1:1 bevel gearbox

1:1 bevel gearbox designed primarily to be used on AB and manual duty IW quarter series gearboxes to change the input shaft direction by 90° for underground applications.

Chainwheels

range



Direct mount chainwheels

Direct mount chainwheels mount directly onto the gearbox input shaft by means of a pin or coupling and are suitable for use with every gearbox range in our product offering.

- Cast iron chainwheels from 135 to 330 mm (5.32 to 13 inch) diameter
- Chain guides and bearing are standard
- Chain and chainwheel sprockets are to DIN 766
- Galvanized or stainless steel chain available
- Epoxy coating for durability available
- **Options:** AISI316 chainwheel & chain, sheradisation protection, adaption design to suit application.

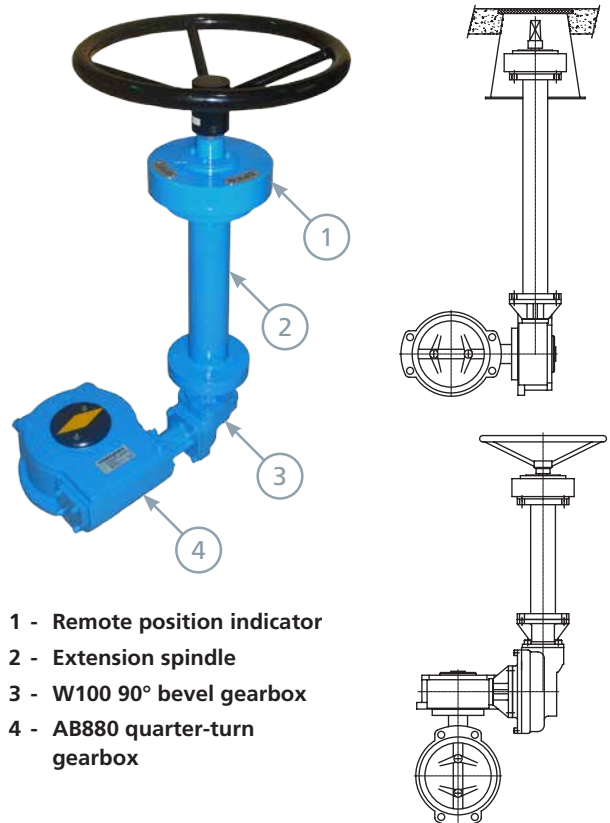

- 1 - Remote position indicator
- 2 - Extension spindle
- 3 - W100 90° bevel gearbox
- 4 - AB880 quarter-turn gearbox

Dead Man's Handle



Spring-return handle

Guarantee failsafe operation for ball valves, the Spring-Return Handle (SRH) will mount on any ball valve, either "direct on" or with a mounting kit designed to suit application.

- Ball valves with torque of 24 or 45.5 Nm
- F03, F05, F07 pcds
- Direct mount or with mounting kit
- Sealed for life, zero maintenance
- Stainless steel handle, shaft and fasteners, precision die cast body
- Durable powder coated finish

Lagging Extensions



Stainless steel lagging extensions

- Butterfly, plug and ball valves from 1/4" to 10"
- 65 to 1,000 mm high
- Stainless steel, with stop and fasteners
- Designed to suit any valve mounting pad
- Optional locking facility
- Tee bar or lever operator
- **Options:** Environmentally sealed, oil filled, bearings, low cost carbon steel.

Indexed Levers

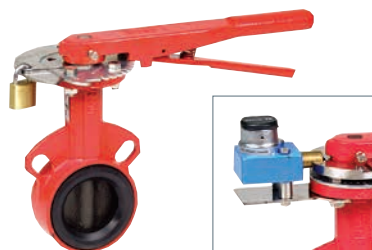

Indexed levers (notch plates)

Indexed levers with stainless steel plates for butterfly valves. Indexed by degrees or open/closed. Supplied with all fasteners and engraved position indication. Padlock and Castell lock options.

SafeOperator™



Flexible valve extensions

Rotork gearboxes combined with Elliott's SafeOperator™ systems provide the flexible solution for the operation of valves located in hazardous or difficult to access locations. System components are available for almost all valve configurations to provide reliable, remote operation up to 30 m (100 feet) away.

Handwheels

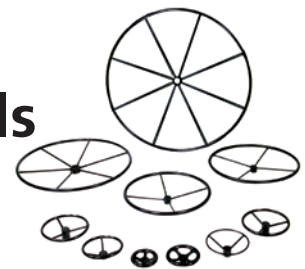

Stainless steel and powder coated handles

- 125 to 2,000 mm diameter
- Stainless steel or powder coated
- Keyed, pinned or square drive
- Fabricated or pressed design
- Oval or round designs for small valves
- Open and closed indication marking
- **Options:** Locking flange, handle, specials, galvanised, rotating handle, flat or dished.

Solenoid Valves

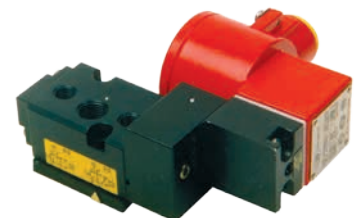

High performance solenoid valves

Rotork Valvekits has available a large range of quality solenoid valves to cover all the range of safe and hazardous areas. These include Exia and Exd in various materials with NAMUR and remote mount options.

Precision Control and Indication

rotork[®] Instruments

Rotork Instruments has production facilities throughout the world, complemented by a large network of distribution and support centres.

Worldwide Industry and Application Experience

With nearly 60 years of extensive knowledge and experience, Rotork has provided products and services worldwide for virtually every industrial actuator application.

Rotork Instruments offers a range of precision control and valve accessory products from Fairchild, YTC, Soldo[®], Midland ACS, Bifold[®] Fluidpower, M&M International and RI Wireless companies:

- Isolation valves
- Pressure regulators and boosters
- Relief valves
- Pilot and manual valves
- Solenoid valves
- Field instrumentation
- Cylinders
- Subsea solenoids
- Ancillary products
- Controls
- I/P transducers
- V/P transducers
- Switchboxes
- Pneumatic positioners
- Electronic positioners and controllers
- Wireless valve monitoring

Rotork Instruments is proud to offer a diverse range of products which serve many different duties in a wide variety of applications. We also offer a factory customisation service, to create one-off units to meet specific needs.

Specialist products for control and measurement of flow and pressure.

Trusted wherever there is a need for high precision and reliability, including oil & gas, pharmaceutical, biomedical, and manufacturing industries.

Bifold[®]

A **rotork** Brand
FAIRCHILD
precision pneumatic & motion control

YTC
A **rotork** Brand

SOLDO
CONTROLS

wireless
ri
A **rotork** Brand

MIDLAND-ACS
A **rotork** Brand

m&m
International
A **rotork** Brand



Precision Control and Indication

Pneumatic Solenoid Valves



Solenoids

Designed and constructed of 316 stainless steel our ranges of pneumatic components are ideally suited for both hazardous areas and industrial use.

- Up to 500 psi / 35 bar working pressure
- 316L stainless steel body construction with conduit, flying lead and NAMUR interface
- Manual reset and manual override options
- Low power consumption version available
- Normally open, normally closed and diverting

Hydraulic Solenoid Valves



Solenoids

- Up to 20,000 psi / 1,380 bar working pressure
- 316L stainless steel body construction
- Manual reset and manual override options
- Low power consumption version available
- Normally open, normally closed and diverting

Industrial Solenoid Valves



Solenoids

- Direct-acting compact valve design - 1/4" to 8" sizes
- Zero pressure rated
- Exd options
- Suitable for vacuum applications

Piston Actuated Valves



Solenoids

- 3/4" to 2" sizes
- 316 stainless steel, brass and bronze body construction
- Thread, flange and clamp connections
- Normally Open, Normally Closed and Bi-directional options

Precision Control and Indication

Pneumatic and Hydraulic Spool Valves



Pilot and manual valves

- 1/4" to 1" sizes with mechanical, air and solenoid operator options
- 3/2 and 5/2 configurations
- 316L stainless steel body construction

Filters, Filter Regulators, Regulators, Flow Control, Volume Boosters and HIPEX Valves



Pressure regulators and boosters

Precision pneumatic regulators including pressure reducing, back pressure and vacuum models.

Volume boosters meet all the requirements of a precision device including accuracy, sensitivity, fast response, stability, drift-free settings, low output droop, Supply pressure effect immunity, high forward and exhaust flow capacity.

- 1/4" to 2" sizes
- 316L stainless steel and aluminium body materials

Hydraulic and Pneumatic Thermal, Check and Precision Relief Valves



Relief valves - gaseous & liquid service ranges

- Hydraulic range up to 1,380 bar working pressure
- Pneumatic range up to 12 bar working pressure
- Pneumatic range includes 1/4" to 1" NPT / BSP pressure relief valves
- Pressure control from 0.8 to 1,200 bar
- Working temperature:
Nitrile -20°C to +80°C
Viton 20°C to +150°C

VDMA Pneumatic Cylinders



Cylinders

VDMA range pneumatic cylinders. A range of double-acting, fully adjustable cushioned metric cylinders to VDMA 24562 and BS ISO 6431 standards. Profile barrels (MP range) or with conventional round barrels (MR range).

- 32 mm to 125 mm bore
- Ports 1/8" to 3/4" BSP
- Simple reliable design
- Meets international and European standards
- Magnetic piston option
- Customer's required stroke supplied as standard
- Adjustable air cushioning
- Lube free
- Full range of mounting accessories
- Customised designs available

Pressure Transmitters



Field instrumentation

- Intrinsically Safe (IS) and Exd ATEX & IECEx certification
- Digital display and pipe mounting options
- IP67 and 316L stainless steel body material
- 0 to 2,200 bar pressure ranges
- 0.25% full scale accuracy

Motor Pumps



Instrument Pumps

- **Chemical injection motor pump unit**
Worldwide approvals ATEX / CE / ISO 9001: 2000.
Flow rates upto 160 l/min @ 155 bar and 46 l/min @ 636 bar.
Designed for use with potentially hazardous chemicals.
Compact multi-piston pumps offer minimal pressure pulsation.
Hermetically tight, environmentally friendly.
- **Chemical metering hydrodrive motor pump unit**
- **Water and oil based fluids pump / motor pump unit**
- **Water pumps and motor pumps units**
Hydraulic pumps for water based fluids
316 stainless steel external components
Type TW :
High Pressure – up to 1,000 bar
Standard version for intermittent operation
Water cooled version for continuous operation
Type SW :
For use with limited power availability – 0.5 to 0.75 kW
24 VDC motor
High pressure up to 690 bar
- **Water glycol pumps and motor pump units**
Type XW up to 1,040 bar
- **Oil pumps** – Type MPU / M / S / XH up to 690 bar with special high pressure version up to 1,000 bar

Instrumentation Ball and Needle Valves

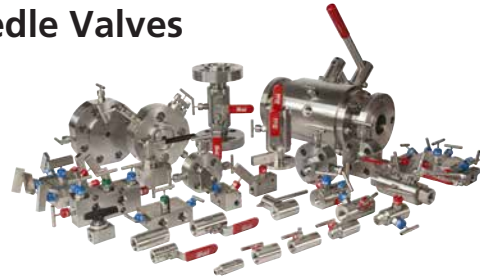

Field instrumentation

One piece body construction 1/4" to 1" NPT 414 bar up to 10,000 psi / 690 bar. Medium pressure range available from 10,000 to 20,000 psi / 1,380 bar.

- **Ball valves:**
State of the art design to reduce potential leak paths with a standard pressure ranging from 1,000 psi / 70 bar up to 10,000 psi / 690 bar, 1/4" to 2" NPT.
- **Double block and bleed monoflange and piping valves:**
Combining piping and instrument valves in a single assembly provides weight and space savings as well as reduction in potential leak paths. Up to and including Class 2500. Available in 1/4", 3/8", 9/16", 3/4", 1".



Ancillaries

Full range of ancillary products in 316L stainless steel specifically designed for severe environments with low temperature options available at -50 °C, to include:

- **Check valves:**
13 bar up to 11 Cv
828 bar up to 190 lpm
690 bar, 51 lpm velocity check
- **Quick exhaust valves:**
Up to 12 bar pneumatic, 1/4" to 2" options available
Ambient temperature range -20 to +70°C
- **Flow regulators:**
Up to 1" NPT uni-directional and bi-directional flow options
- **Air pressure switches:**
Latch lock manual reset option
3/2 or 5/2 options
Thermal fuses – 1/2" NPT up to 200 °C

Precision Control and Indication

Electro-Pneumatic Transducers



Controls

Accurate, compact I/P, E/P, D/P & P/I electro-pneumatic transducers with extensive combinations of inputs and outputs carry standard FM, CSA, ATEX or IECEx agency approvals and maintain accuracies up to 0.15% and feature proportional pressure regulation.

- Accuracy: As low as + 0.15% full scale
- Repeatability: As low as + 0.1% full scale
- Max supply pressure: 1,380 kPa (200 psi)
- Max output pressure: 1,050 kPa (150 psi)
- Flow capacity: 15.3 to 1,189 m³/hr (9 to 700 SCFM)
- Pipe sizes NPT: ¼" to 1"

Electronic Controls



Controls

Explosionproof (Ex) and intrinsically safe (IS) range provides – control of electro-hydraulic actuators. Incorporating:

- HART protocol
- Remote control options
- 316L stainless steel option
- Suitable for Zone 0, 1 & 2 hazardous environments

Pneumatic Positioners



Controls

YT-1200, YT-1200L positioners are used for pneumatic valve actuators by means of a pneumatic controller or control systems with an output signal of 3 to 5 psi or split ranges.

- The product can operate normally in a very extreme environment, such as vibration and temperature
- Durability testing for a minimum of 2 million cycles
- Response time is very short and accurate
- Simple part change can set 1/2 split range
- It is economical due to less air-consumption
- Direct / reverse action can be set easily
- Zero and span adjustment processes are simple
- Feedback connection is easy

Limit Switchboxes and Sensors



Controls

- **General purpose and intrinsically safe switchboxes**
Polymer, aluminium or stainless steel enclosures
Corrosion resistant enclosures NEMA 4/4X (IP65)
- **Explosionproof limit switchboxes**
Aluminium or stainless steel enclosures
Explosionproof certification; Certification options:
UL, ATEX, INMETRO, CCOE, GOST, IECEx, SIL
- **Integral solenoid valve limit switchboxes**
Aluminium enclosure – designed to meet NEMA 4/4X (IP65)
AS-i interface or DeviceNet capable
- **BOLT proximity sensors.** Threaded body proximity switch for remote electrical indication of linear and rotary valve / actuator position

Wireless Valve Monitoring

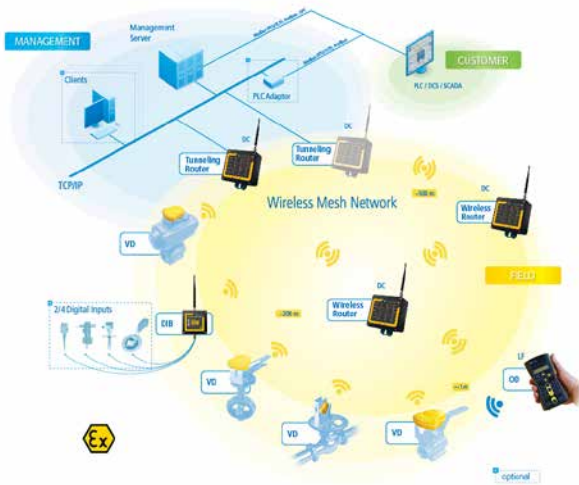

Controls

- Self-powered sensors
- Wireless redundant mesh network
- Hand-held configurators
- Interface to SCADA/PLC/DCS

Specialist Freight Rail Wagon Door Systems



Controls

- Double-acting, fully adjustable cushioned metric cylinders to VDMA 24562 and BS ISO 6431 standards



Photo credit: Drax Biomass

Pneumatic and Hydraulic Manifolds

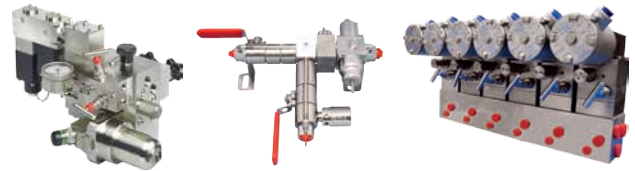

Controls

Compact manifold

Axis stacker manifold

Hydraulic manifolds

- High flow rates up to 200 l/min (45 gpm)
- Low cost
- 316L stainless steel
- 1/4", 3/8", 1/2", & 1" thread milled NPT
- Offering reduction in cost and weight and an increase in performance

Subsea Valves and Controls



Subsea

Shuttle valves – up to 690 bar

Pilot operated valves – Ball seated and slide up to 1,035 bar

Pilot operated valves (shear plane sealing) – up to 690 bar

Solenoid valves – up to 690 bar

Special valve products

Control pod products

- Valves for operation directly immersed in sea water to 3,000 m / 1,035 bar / -40 to +121 °C
- Extensive qualification test programmes
- 1 million cycles operation
- Option of seawater as operating medium
- Up to NAS 1638 Class 12
- Leakage 0 to 0.2 cc/min
- 18 to 28 VDC, 15 Watt



Integration of the plant controls by use of network connectivity has been a hallmark of Rotork's actuator products for many years. The use of proprietary and open systems makes the commissioning of the plant and the subsequent control and monitoring a simple and reliable task.

All Rotork actuators are compatible with a wide range of communication and process controls systems by including the appropriate option card. The actuator reports status feedback, via the field highway, to the overall plant control system (DCS or PLC) and valve control commands are actioned.

Our own *Pakscan*[™] system complements the open systems from Foundation Fieldbus®, Profibus®, Modbus®, HART® and DeviceNet®. Innovative technology together with expert bus system knowledge ensures that Rotork can always provide the ideal solution for the control system.

A full listing of our worldwide sales and service network is available on our website at www.rotork.com

Modern facilities require up to date communications 24 hours a day, right down to plant level.

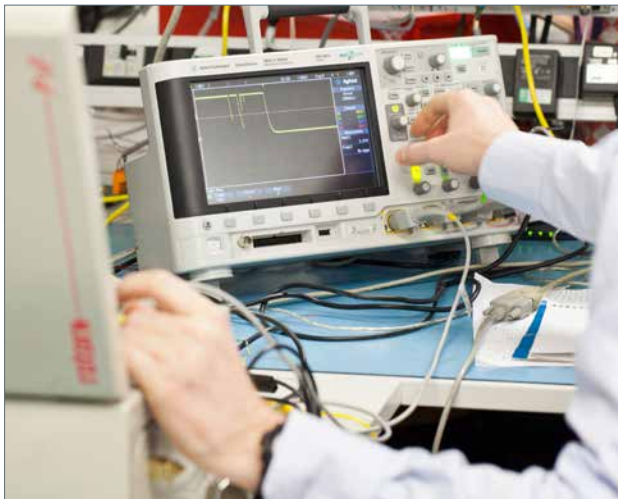

Pakscan[™]

The Rotork *Pakscan* system is the world leader in actuation control automation. *Pakscan* continues to be at the forefront of network technology, helping to control over 150,000 field units. *Pakscan*'s superior technology keeps it ahead of the competition.

Now with 30 years installed experience *Pakscan* has found preference in all industry sectors and many diverse applications.

The Rotork P4 Master Station and *Pakscan Plus* network have been designed for use in all industries and applications where robust and reliable plant control and monitoring is required.

The *Pakscan* system introduces an ultra fast *Plus* network for immediate response and data acquisition along with backward compatibility with traditional *Classic* and *Wireless* networks and support for Modbus field networks.

Pakscan, comprehensive solutions for modern plant control and monitoring.

See PUB059-048 for further details.

P4 Master Station with intuitive touch screen user interface

Asset management and datalogging

Up to four field networks on one master station

Existing Pakscan systems upgradeable to P4 Master Station

Pakscan Plus, the fastest dedicated actuator control network

All Pakscan field networks open to 3rd party devices

High-availability Seamless Redundancy (HSR)

Efficient low cost install with minimum cost of ownership

Multiple host connectivity

Over 150,000 existing installed Pakscan field devices

Pakscan System

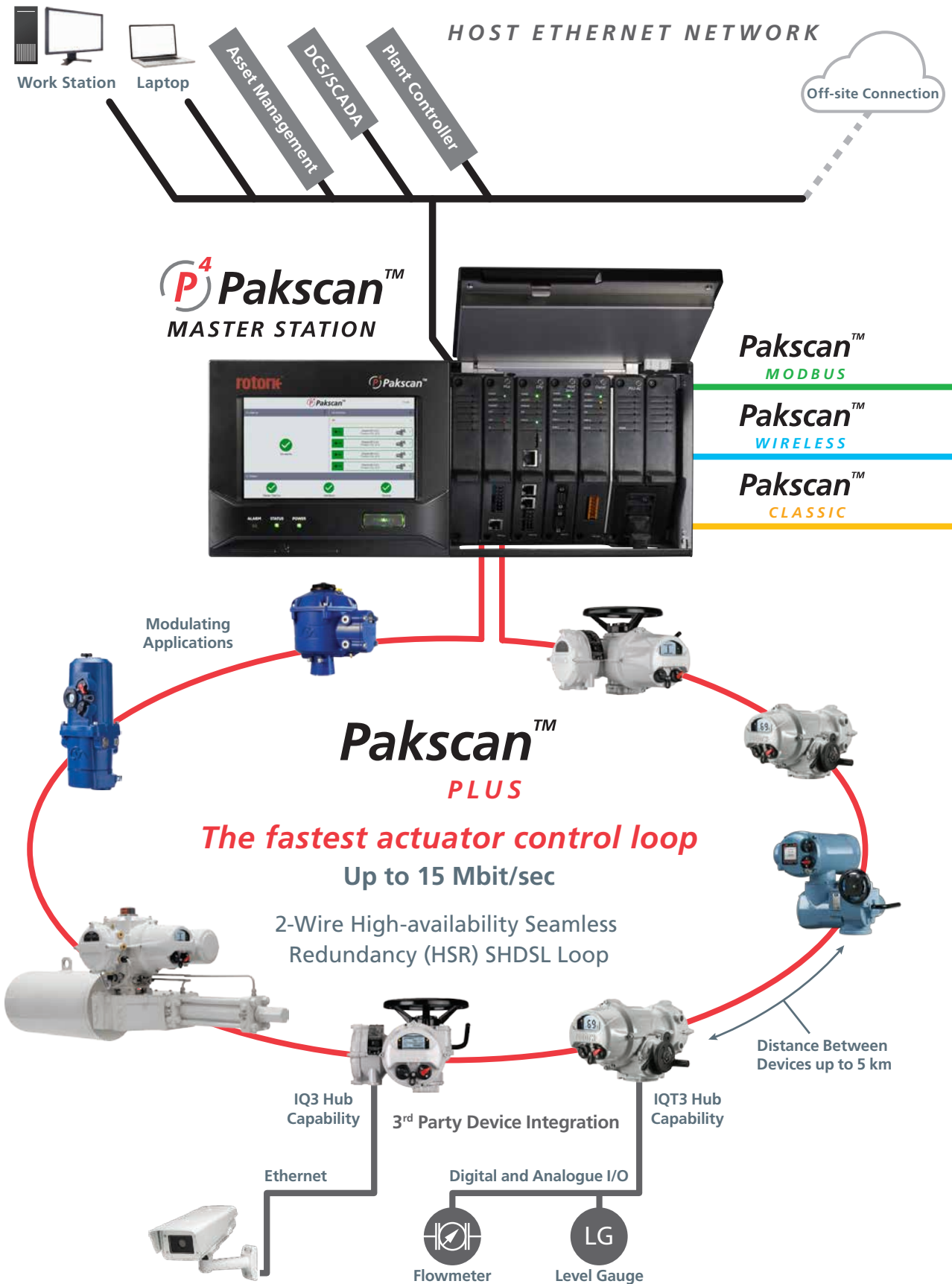

Multiple Bus Connectivity

Multiple fieldbus connectivity

Rotork actuators are compatible with most industry standard fieldbus systems via network cards that are fitted in the main electronics enclosure.



Foundation Fieldbus®

Foundation Fieldbus has become widely accepted for use in process control systems. Its primary feature is the ability to distribute control away from the central DCS. The Rotork Foundation Fieldbus interface card connects directly onto the standard Foundation H1 bus system. The function blocks embedded in the module cover the control and monitoring of the valve and actuator. Using the certified Device Description files the FF card is simple and easy to use. The ability to report extensive actuator feedback within a single input block as well as system diagnostic information makes Rotork the first choice for use with a Foundation Fieldbus system.

- Foundation ITK inter-operability certified
- Fully compliant with IEC61158-2 standard
- Includes link master and LAS capability
- Independent HIST approval by major DCS vendors
- Full H1 field capability

See PUB089-001 for further details.

Profibus®



Profibus is a leading international network protocol for high speed data communications in industrial automation and control. The Rotork Profibus DP interface card provides comprehensive control and feedback data about the valve and actuator using DP-V0 cyclic communications whilst extended actuator diagnostics and configuration is included in the DP-V1 acyclic data supported by this module. EDD and DTM files allow the Rotork device to be incorporated into asset management systems giving access to performance critical parameters, whilst the independently certified GSD file guarantees device interoperability. Rotork provides an optional switch disconnect module allowing for ease of installation and have multiple configuration options within the GSD file to enable a choice of data collection.

- RS485 Profibus DP V0 and V1 compliant
- Single and Dual Redundant options
- Fully meets IEC61158-3 standard
- Profibus PNO certified
- Supports speeds up to 1.5 Mbit/s

See PUB088-001 for further details.

DeviceNet®



DeviceNet is an Open Network Standard for communication networks using the main features of CAN bus in an industrial environment. The Rotork DeviceNet interface module provides easy access to actuator process control and feedback information. The Electronic Data Sheet (EDS) description file is used to set up the actuator parameters to allow the system's performance to be optimised. In addition to the standard actuator torque and position feedback a further analogue input is included as standard enabling integration of external analogue equipment onto the network. The Rotork module has been certified by the Open DeviceNet Vendor Association to ensure its interoperability with other devices.

- Up to 63 devices on each network
- 4-wire cable, 2 for signal, 2 for power
- Trunk and drop line permitted
- ODVA certified to ensure compatibility
- EDS electronic device description file

See PUB090-001 for further details.

Modbus®

Modbus®

Modbus remains the most popular process communication protocol in use today with the widest acceptance and highest number of applied systems of any automation protocol.

Rotork's Modbus interface card allows actuators to be connected to a 2-wire RS485 network for direct communication to a PLC or DCS using Modbus RTU protocol. The resulting network is able to monitor and control the connected actuator. As the Modbus protocol is so simple the system engineer has full control over the data flow on the highway and the information to be collected and controls implemented. There are no complications with device description files or special programming tools required when setting up a Modbus system.

- RS485 2-wire RTU communication
- International open standard
- Single and dual redundant options
- Integral repeater modules included where necessary
- Up to 115 kbps

See PUB091-001 for further details.



HART®

HART (Highway Addressable Remote Transducer) is a process control communication protocol based upon the Bell 202 telephone communication standard and uses the FSK (Frequency Shift Keying) principle. The signal consists of two parts, the analogue 4 to 20 mA current loop and a superimposed digital variable frequency signal. Traditionally the 4 to 20 mA loop is used for control and the superimposed digital signal for feedback, diagnostics and configuration. Configuration and feedback using the HART digital signal can be achieved using the host connected to the actuator to select the parameters required. The majority of the user configurable settings can be made over the HART communication protocol.

- Up to 63 devices on each network
- Electronic Device Description (DD) files
- HART 7 compatible

See PUB092-001 for further details.

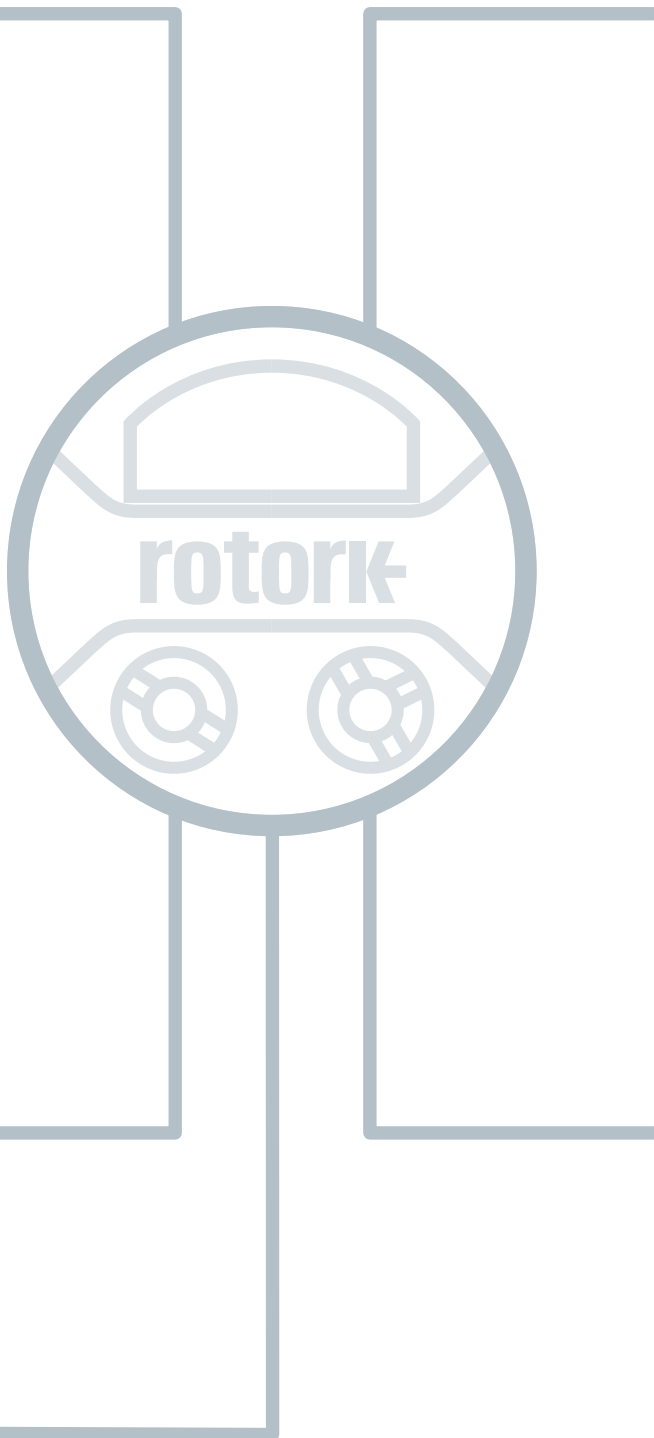

Client Support and Site Services

rotork® Site Services

Rotork actuators are recognised as the best in the world for reliability and safety in the most demanding applications. To maintain this hard-earned leadership position, Rotork Site Services is committed to helping clients to maximise the continuous, fault-free operation and working life of all their actuators.

With established operations and worldwide service centres we are able to offer same-day or next-day service to all our customers. Our Rotork factory trained engineers have skills in both multi-purpose and industry specific applications and carry with them spare parts and specialist test equipment. Our operations utilise a documented Quality Management system established in accordance with ISO9001.

Rotork Site Services aims to be your number one choice for taking care of fault diagnosis, service repairs, scheduled maintenance and system integration needs.

Rotork has expertise and specialist knowledge of every aspect of flow control.

Our service solutions increase plant efficiency and reduce maintenance costs.

Workshop services return equipment to as-new condition.



Client Support and Site Services

Client Support Programme

Rotork offers a tailor-made service of planned maintenance aimed at the prevention of breakdowns and failures. The primary goal of our Client Support Programme (CSP) is to prevent the failure of equipment before it can occur. This includes equipment checks, replacement of worn components and partial or complete overhauls at specified periods.

Planned preventative maintenance is a better alternative to risking a potentially damaging breakdown of equipment, and enables our customers to realise the full potential of their business by ensuring the maximum reliability and availability of our products. Wherever our customers are, Rotork is able to support them. We have workshops strategically located around the world, with trained staff and full test and maintenance facilities.

As part of the CSP, customers have 24/7 access to the Rotork Support Centres, with priority technical assistance, backed by comprehensive website resources and priority software support. With over 410 Rotork engineers and additional service technicians employed by our agents, we have the infrastructure required to effectively support all of our customers' needs.

Through consultation, the Client Support Programme is tuned to deliver the optimum level of maintenance through predictive maintenance algorithms.

Through CSP, Rotork provides a premium level of product reliability and availability.

The predictive maintenance strategy is designed to facilitate the highest production demands while providing a tiered approach to maintenance, the Client Support Programme is committed to reducing maintenance downtime and costs.



Features of the Client Support Programme are:

- Fixed term prices for Rotork products and services
- Customisable cover based on equipment criticality to production
- Equipment performance related targets for reliability and availability
- Priority support with customisable response times
- Fully parts and labour inclusive or discounted labour and parts
- Fix or replace options
- Periodic equipment performance and status reports
- Built-in regular health checks on all equipment

Benefits of the Client Support Programme include but are not limited to:

- Year-on-year reduced maintenance costs
- Easy budget management
- Maximised production – reduced downtime
- Year-on-year improved reliability and availability
- Optimised resource usage, accelerate in-house projects
- Reduced lifecycle costs

The Client Support Programme covers service and on-site repairs of all brands of actuators for the Power, Water, Utilities and Oil & Gas Sectors.

For further information, or to arrange a consultation please contact one of our dedicated sales team or service managers.



Client Support and Site Services

Global Service and Support

Rotork understands the value of prompt and punctual customer site services and aim to supply our customers with superior flow control solutions, by providing high quality, innovative products and superior service – **on time, every time.**

Whether you have an actuator requiring on-site servicing, a custom design service requirement or a new actuator installation, we can deliver the fastest turnaround with the least plant disruption.

Actuator Workshop Overhaul

- Supporting all Rotork and non-Rotork products
- Workshop facilities including torque testing and re-coating
- Large OEM stock in all workshops
- Fully trained and experienced service engineers
- Loan actuator facilities

Field Support

- Site repairs
- Commissioning
- Upgrades
- Fault finding
- Maintenance planning and scheduling
- Call-out
- Fully equipped service vehicles

Turnaround, Shutdown and Outage Support

- Preventative maintenance
- Full on-site overhaul and testing facilities
- OEM spares and support
- Support for Rotork and non-Rotork products
- Commissioning support to achieve shutdown time targets
- Project management and supervision of your plant overhaul and return to service dates

Valve Automation Centres:

On-site – Manual Valve Automation

- Full design, manufacture, supply and installation services to automate your existing manual valves, penstock or dampers
- Power Supplies, UPS, Distribution Boards, MCCs
- System Integration
- Control system design, PLC, bus systems, logic, flow control systems, PID control, failsafe critical plant
- Full Mechanical, Electrical, Instrumentation, Control and Automation (MIECA) installation by our own qualified installation team

On-site – Actuator Replacement

- Replacement of obsolete or ageing actuators in the field with the latest Rotork product range
- Correct product selection for the right application
- Design and manufacture of adaption components
- Electrical interface design and installation
- Fully commissioned to the plant control room
- Extended warranty on all products installed by Rotork technicians

Off-site – Vew Valve Automation

- Automation of new or refurbished valves in our dedicated service centre
- Correct product selection to suit the process demands
- Design and manufacture of all engineered components
- Correct assembly of valve and actuator/gearbox combinations
- Selection and procurement of the preferred or specified valve for your application
- Free issue valves accepted for automation in our service centres
- Packed and shipped to your client on your behalf



Client Support and Site Services

Accreditation and Assurance

Rotork Site Services is accredited with all major safety authorities around the world, providing our clients with reassurance and peace of mind.

Rotork's engineering teams are experts in the design and implementation of actuation solutions for all circumstances and environments. Our knowledge base draws upon previous installations and environmental situations from all around the world.

Our track record of undertaken engineering projects is second to none. Rotork is trusted by major utility and industrial companies throughout the world to design, install and maintain their actuation stock. We keep their plants operating at peak efficiency, helping them to be more profitable and at the same time meet ever tightening industry watchdog requirements.

We have the knowledge and expertise to design, build and install any standard or custom installation for you, anywhere throughout the world.

Asset Management

Rotork is a corporate member of the Institute of Asset Management, the professional body for whole life management of physical assets.

*Giving You Peace of Mind,
Guaranteed Quality and
Improving Your Site Efficiency*



rotork®

Keeping the World Flowing

www.rotork.com

A full listing of our worldwide sales and service network is available on our website.

Rotork plc
Brassmill Lane, Bath, UK
tel +44 (0)1225 733200
email mail@rotork.com

Rotork is a corporate member of the Institute of Asset Management



PUB000-002-00
Issue 11/16

As part of a process of on-going product development, Rotork reserves the right to amend and change specifications without prior notice. Published data may be subject to change. For the very latest version release, visit our website at www.rotork.com

The name Rotork is a registered trademark. Rotork recognises all registered trademarks. The *Bluetooth*® word mark and logos are registered trademarks owned by *Bluetooth* SIG, Inc. and any use of such marks by Rotork is under license. Published and produced in the UK by Rotork Controls Limited. POWTG1116